

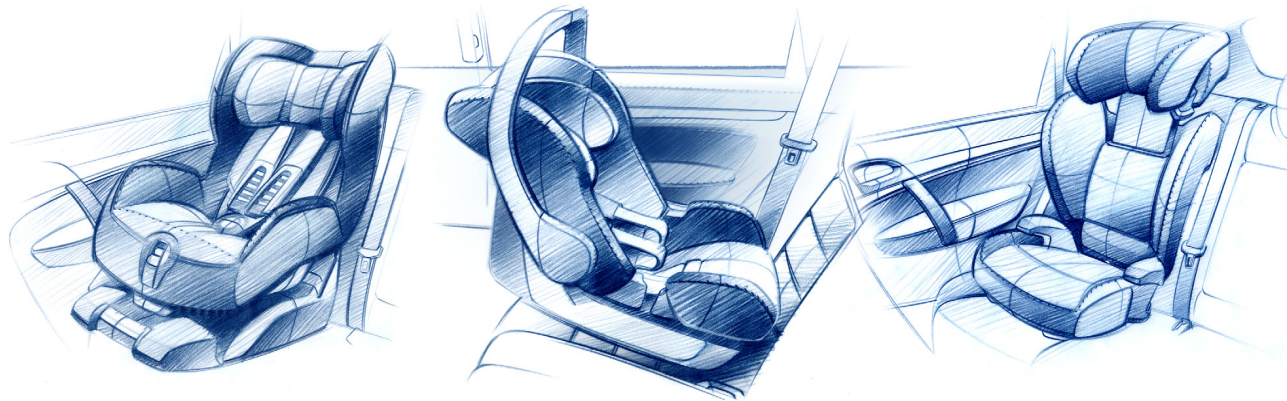

**PORSCHE**



## **Tequipment**

### **Operating Instructions**

**Porsche Baby Seat LATCH, G0+**

**Porsche Junior Seat LATCH, G1**

**Porsche Junior Plus Seat, G2 + G3**

Porsche, the Porsche Crest and  
Equipment are registered trademarks  
of Dr. Ing. h.c. F. Porsche AG.

Reprinting, even of excerpts, or duplication of any  
type is only permissible with the written authorisa-  
tion of Dr. Ing. h.c. F. Porsche AG.

Errors and modifications of design, equipment  
and scope of delivery as well as differences in  
colour and materials are reserved.

Deviations from the described product contents  
are possible in various countries due to country-  
specific regulations and statutory requirements.

Dr. Ing. h.c. F. Porsche  
Aktiengesellschaft  
Stuttgart-Zuffenhausen

Version: April 2014  
Printed in Germany

**Dear Customer,**

congratulations on the purchase of your new Porsche child restraint. This operating instructions provided for your information and to assist you with the installation and use of your Porsche child restraint. In order that you better understand the safety and comfort issues associated with Porsche child restraint, Porsche recommends that you read this operating instructions carefully before installing or using a child restraint in your Porsche vehicle.

This operating instructions describes the following Porsche child restraints.



**Porsche Baby Seat LATCH, G0+**

Valid only for children whose weight is 29 pounds (13 kg) or less and height is 31 inches (80 cm) or less.



**Porsche Junior Seat LATCH, G1**

Valid only for children who weigh between 20 - 40 pounds (9 - 18 Kg) and whose height is between 31 - 38 inches (80 - 97 cm).



**Porsche Junior Plus Seat, G2 + G3**

Valid only for children who weigh between 40 - 80 pounds (15 - 36 Kg) and whose height is 60 inches (152 cm) or less.

### Installation in your vehicle

If you have any questions concerning the installation and safe operation of Porsche child restraint, your Porsche Dealership Sales and Service personnel can assist and advise you.

This operating instructions is valid in the United States.

Observe the safety notes in the chapter "Child restraint systems" of the vehicle Owner's Manual when using the Porsche child restraint.

The Porsche child restraint seat should always be used on the rear seat of the vehicle.

### Safety instructions in the Operating Instructions

Various types of safety instructions are used in this Owner's Manual.

#### **DANGER**

Serious Injury or Death

Failure to observe safety instructions in the "Danger" category will result in serious injury or death.

---

#### **WARNING**

Possible Serious Injury or Death

Failure to observe safety instructions in the "Warning" category could result in serious injury or death.

---

#### **CAUTION**

Possible Moderate or Minor Injury

Failure to observe safety instructions in the "Caution" category can result in moderate or minor injury.

---

#### **NOTICE**

Possible child restraint Damage

Failure to observe safety instructions in the "Notice" category could result in damage to the vehicle.

---



#### **Information**

Additional information, tips, and instructions are indicated by the word "Information". Please read this information carefully and follow the instructions.

---

### Orientation guides in the Operating Instructions

The orientation guides in the Operating Instruction are highlighted in yellow.



## General Content

<b>General Safety Information .....</b>	<b>5</b>	Installing your child restraint correctly .....	28	<b>Porsche Junior Seat LATCH.....</b>	<b>41</b>
		Removing the child restraint with		Content .....	43
		Lap Belt .....	29	Safety Information .....	44
		Fitting the Sun Shade .....	30		
<b>Porsche Baby Seat LATCH.....</b>	<b>9</b>				
Content .....	11				
Safety Information.....	12				
		<b>Cleaning and Maintenance</b>		<b>Installation instructions</b>	
<b>Installation instructions</b>		Cleaning .....	32	Installation instructions .....	46
Installation instructions .....	14	Removing the Cover .....	32	How to use your Porsche	
How to use your Porsche Baby		Fitting the Cover .....	34	Junior Seat LATCH .....	46
Seat LATCH .....	14	Removing the Belts .....	35	The Porsche Junior Seat LATCH may	
The Porsche Baby Seat LATCH may be		Installing the Belts .....	36	be used in the listed vehicles .....	47
used in the listed vehicles .....	15	Care instructions for the belt buckle .....	38	Installing the Child Seat with	
Secure your child in place .....	16	Care instructions for the		LATCH Fastening System .....	48
Removing the Support Cushion .....	16	LATCH belt buckles.....	39	Removing the Child Seat with	
Adjusting the Carrying Handle .....	16			LATCH Fastening System .....	50
Adapting the Headrest .....	18			Correct Installation of the Child Seat	
Adjusting the Headrest .....	18			with LATCH Fastening System .....	50
Loosening the shoulder belts .....	19			Installing the Child Seat with	
Buckling in your Baby .....	19			LATCH Fastening System and top tether .....	51
Securing your Child properly.....	21			Removing the Child Seat with LATCH	
Fastening in the vehicle .....	22			Fastening System and top tether .....	54
Fastening the child restraint with				Correct Installation of the Child Seat	
LATCH System .....	22			with LATCH Fastening System	
Installing your child restraint correctly .....	23			and top tether .....	55
Removal the child restraint with				Installing the Child Seat with	
LATCH System .....	24			Three-Point Seat Belt.....	56
Fastening the child restraint with				Removing the Child Seat with	
the Three-Point Seat Belt .....	24			Three-Point Seat Belt .....	58
Installing your child restraint correctly .....	26			Correct Installation of the Child	
Removing the child restraint with				Seat with Three-Point Seat Belt .....	59
the Three-Point Seat Belt .....	27				
Fastening the child restraint with					
a Lap Belt .....	28				

## General Content

### Porsche Junior Seat LATCH (continue)

Installing the Child Seat with Lap Belt and top tether .....	60
Removing the Child Seat with Lap Belt and top tether .....	63
Correct Installation of the Child Seat with Lap Belt and top tether .....	64
Adapting the Headrest .....	65
Adjusting the Headrest .....	65
Buckling in your Child .....	66
Securing your Child properly .....	67
Idle Position of the Child Seat .....	68

### Cleaning and Maintenance

Cleaning .....	69
Removing and Fitting the Covers .....	69
Removing the Headrest Cover .....	70
Removing the Seat Cushion Cover .....	70
Fitting the Covers .....	72
Removing the Belts .....	72
Installing the Belts .....	74
Buckle Care .....	77

### Porsche Junior Plus Seat ..... 79

Content .....	81
Safety Information .....	82

### Installation instructions

Installation instructions .....	84
How to use Porsche Junior Plus Seat .....	84
The Porsche Junior Plus Seat be used in the listed vehicles .....	85
Components of the Porsche Junior Plus Seat .....	86
Fastening the Backrest .....	86
Seat Cushion Width .....	87
Adjusting the Seat Cushion Width .....	87
Headrest .....	88
Adjusting the Headrest .....	89
Adjusting the reclining position of the Backrest .....	89
Buckling in your Child .....	90
Fastening the Seat Belt .....	90
Securing your Child properly .....	93
Unfasten the Seat Belt .....	93

### Cleaning and Maintenance

Cleaning .....	95
Removing and Fitting the Covers .....	95
Removing the Backrest Cover .....	96
Removing the Seat Cushion Cover .....	96
Removing the Armrest Cover .....	96
Removing the Headrest Cover .....	97
Fitting the Covers .....	97

### Instruction for disposal ..... 98

### Recall Information USA ..... 99

### Limited Warranty USA ..... 99

## General Safety Information

General Safety Information applies to the following Child restraint systems:

- Porsche Baby Seat LATCH
- Porsche Junior Seat LATCH
- Porsche Junior Plus Seat

Porsche recommends that all infants and children be restrained in child restraint systems at all times while the vehicle is in motion in accordance with applicable laws.

Use only child restraint systems recommended by Porsche. These systems have been tested and adjusted to the interior of your Porsche and the appropriate child age groups. Other systems have not been tested and could entail an increased risk of injury.

### DANGER

Improper Installation or Use

Serious Injury or Death can occur due to improper installation or use of Porsche child restraints.

- ▷ Porsche child restraints are designed to be secured with the vehicle belt restraint or LATCH systems as specified in these instructions.
- ▷ Read through this Operating Instructions and the vehicle Owner's Manual carefully. Pay particular attention to the "Child restraint systems" sections in vehicle Owner's Manual.

### WARNING

Seat Adjustment while Driving

Risk of serious injury or death possible due to loss of control of the vehicle if you are distracted from driving.

- ▷ Never make any adjustments on the Porsche child restraint while driving.
- ▷ When infants and young children are to be transported in your vehicle, ensure that their child seats or other restraint devices are properly installed and adjusted **before** starting your Porsche vehicle.

**⚠ WARNING**

To reduce the risk of serious or fatal injury to a child in the event of an accident, sharp braking maneuvers or sudden changes of directions:

- ▷ Always secure children in restraint systems appropriate for the size and weight of the child. Never allow a child (or children) to sit on another occupant's lap while traveling in the vehicle. Due to the powerful forces involved, a child (or children) sitting on the lap of another vehicle occupant cannot be restrained in the event of an accident sharp braking maneuvers or sudden changes of direction. The child (or children) could be thrown against parts of the vehicle interior and be seriously or even fatally injured.
- 

**⚠ WARNING**

Do not leave children unattended in the vehicle, even if they are secured in a child restraint system. The children could:

- ▷ injure themselves on parts of the vehicle
  - ▷ be seriously or fatally injured as a result of prolonged exposure to extreme heat or cold
  - ▷ injure other persons by operating the power windows, the sliding sunroof, the power seats or other vehicle functions, depending on the vehicle's equipment.
  - ▷ If the children open a door, they could:
  - ▷ injure other persons
  - ▷ get out of the vehicle and injure themselves or be injured by a passing vehicle or other.
- 

**⚠ WARNING**

According to accident statistics, children in a suitable child seat are better protected when the child seat is properly installed in one of the rear seats rather than on the front passenger seat. You should therefore install the child seat preferably on one of the outer seats in the rear. Otherwise, the chances of a child being seriously or fatally injured in the event of an accident, sharp braking maneuvers or sudden changes of direction will be increased.

---

**⚠ WARNING** Safety Function

Loss of safety function.

- ▷ Regularly inspect all important parts for signs of damage. Make sure that the mechanical components function properly.
  - ▷ The child restraint must be replaced if it was damaged or was stressed in an accident.
  - ▷ If your child restraint, or individual parts of it (e.g. seat cover, etc.) are damaged (e.g. after falling, the seat must be checked by a qualified specialist workshop and, if necessary, replaced.
  - ▷ Do not guide the belt straps of the safety belt over sharp edges. Belt straps in contact with sharp edges become damaged or torn as a result.
  - ▷ Make sure that the child restraint is not trapped between hard parts (vehicle door, seat rails, etc).
  - ▷ Never use a child restraint without prior knowledge of its history as you may never be certain whether it meets original manufacturer specification (e.g. accident damage, pending recalls, pieces missing, etc.).
- 

**⚠ WARNING**

Only allow children to get into or out of the vehicle on the side furthest away from traffic.

---

**⚠ WARNING**

Danger of severe or mortal injuries if there are unsecured persons or objects in the vehicle. Make sure that

- ▷ the backrest of the vehicle is locked.
  - ▷ all heavy and sharp-edged parts in the vehicle are secured.
  - ▷ all people in the vehicle are secured.
  - ▷ you secure the child restraint with the three-point seat belt or the LATCH fastening system when it is not in use.
- 

**⚠ WARNING**

Risk of serious personal injury or death to the child. Follow all child restraint instructions, warnings in this manual and the warnings which are labeled on the child restraint system.

- ▷ When using an infant or child restraint system, be sure to follow all manufacturer's instructions on installation and use.
  - ▷ Infants and small children should never be held on the lap, nor should they share a safety belt with another occupant while the vehicle is in motion.
  - ▷ Children too big for child restraint systems should use regular safety belts. A shoulder belt can be used providing it does not cross the face or the neck of the child.
-

 **WARNING**

Danger of severe or mortal injuries if the following instructions are not followed.

- ▷ Never use this child restraint with motorized belts, belts with attachments in the vehicle door or side facing seats.
  - ▷ The child restraint may only be installed in the location specially designated by the vehicle manufacturer. Please also comply with the vehicle Operator's Manual.
-



PORSCHE

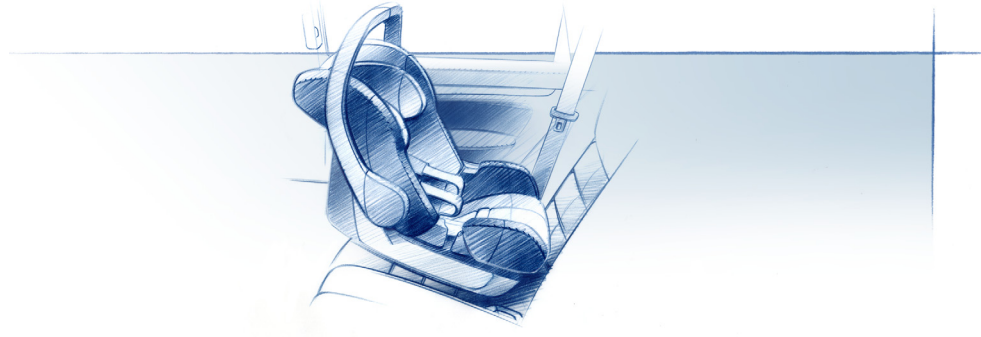

**Operating Instructions  
Porsche Baby Seat LATCH GO+**

**Thank you for purchasing your new Porsche Baby Seat LATCH. How to use and take care of your child restraint plays an important role in the child's safety. Please take the time to read these operating instructions carefully and keep them with the child restraint.**

These operating instructions provide you with important information on how to safely install and use the Porsche Baby Seat LATCH.



**Porsche Baby Seat LATCH**



# Content

## Safety Information

Safety Information ..... 12

## Installation instructions

Installation instructions ..... 14

How to use your Porsche Baby

Seat LATCH ..... 14

The Porsche Baby Seat LATCH may be

used in the listed vehicles ..... 15

Secure your child in place ..... 16

Removing the Support Cushion ..... 16

Adjusting the Carrying Handle ..... 16

Adapting the Headrest ..... 18

Adjusting the Headrest ..... 18

Loosening the shoulder belts ..... 19

Buckling in your Baby ..... 19

Securing your Child properly ..... 21

Fastening in the vehicle ..... 22

Fastening the child restraint

with LATCH System ..... 22

Installing your child restraint correctly ..... 23

Removal the child restraint

with LATCH System ..... 24

Fastening the child restraint with

the Three-Point Seat Belt ..... 24

Installing your child restraint correctly ..... 26

Removing the child restraint with

the Three-Point Seat Belt ..... 27

Fastening the child restraint

with a Lap Belt ..... 28

Installing your child restraint correctly ..... 28

Removing the child restraint with Lap Belt ..... 29

Fitting the Sun Shade ..... 30

## Cleaning and Maintenance

Cleaning ..... 32

Removing the Cover ..... 32

Fitting the Cover ..... 34

Removing the Belts ..... 35

Installing the Belts ..... 36

Care instructions for the belt buckle ..... 38

Care instructions for the

LATCH belt buckles ..... 39

## Safety Information

### Child restraint on the front passenger seat

If you intend to use a child restraint on the front passenger' seat please refer to the vehicle Owner's Manual chapter „Child restraint systems“.

If your vehicle is equipped with a passenger airbag off system please take note of the green „AIRBAG OFF“ symbol on your child restraint.



If your vehicle is **not** equipped with a passenger airbag off system please take note of the red, circle and slash „AIRBAG OFF“ symbol on your child restraint.



If in doubt please see your authorized Porsche dealer.

#### WARNING

Danger of severe injuries if you abruptly change the direction of travel, brake heavily or have an accident.

- ▷ The child restraint's protective function is only ensured when the child restraint is both installed and used properly.
- ▷ Therefore, be sure to precisely follow each individual step of the operating instructions. Comply with the warning notes and safety precautions as well as the corresponding sections in the vehicle Owner's Manual.
- ▷ You should pay particular attention to the information on the safety belts, airbags and child restraint system.

#### DANGER

##### Passenger Airbag

Passenger airbags can cause severe or mortal injuries to children when they are triggered.

- ▷ In all vehicles, it is impermissible to use the child seat on the front passenger seat without deactivating the passenger airbag.
- ▷ If your vehicle is equipped with a passenger airbag off system please take note of the green „AIRBAG OFF“ symbol on your child restraint.
- ▷ If your vehicle is **not** equipped with a passenger airbag off system please take note of the red, circle and slash „AIRBAG OFF“ symbol on your child restraint.
- ▷ Please observe the chapter “Child restraint systems” in the vehicle Owner's Manual.

#### WARNING

If the passenger front airbag is not switched off, only install the child safety seat in one of the rear seats that is suitable for this purpose.

- ▷ Please observe the chapter “Child restraint systems” in the vehicle Owner's Manual.
- ▷ If in doubt please see your authorized Porsche dealer.

#### WARNING

Deactivated passenger airbags do not provide any protection in an accident.

- ▷ Reactivate the passenger airbag after removing the child seat.

#### WARNING

Passenger airbags can cause severe or mortal injury to children when they are triggered.

- ▷ In all vehicles, it is impermissible to use the child seat on the front passenger seat without deactivating the passenger airbag.

**⚠ WARNING**

Danger of severe injuries if you abruptly change the direction of travel, brake heavily or have an accident.

- ▷ The child restraint may only be installed in a rearward-facing direction inside the vehicle.
  - ▷ Make sure that the child restraint's shoulder belts and belt buckle fit snugly against the child's body and are not twisted.
  - ▷ If you use the child seat on the rear seat (**not 911**), move the front seat as far forward as possible, so that the child does not come into contact with the front seat.
  - ▷ Position the front seat backrest vertically.
  - ▷ No modification may be made to child restraint, the safety belts or the fastening points.
  - ▷ Since the cover represents an important part of the safety function, the child seat must not be used without the cover.
- 

**⚠ CAUTION**

Hot Plastic Parts

Danger of burns by hot plastic parts on the child seat if the seat was exposed to the sun.

- ▷ Protect the child seat against exposure to intense sunlight.
- 

**NOTICE**

Damage of child restraint. The child restraint is designed for transporting children.

- ▷ Do not place any heavy or sharp-edged objects in or on the child restraint, even if it has been removed from the vehicle.
- 

**⚠ WARNING**

Unsecured persons or objects

Danger of severe or mortal injuries if there are unsecured persons or objects in the vehicle.

Make sure that

- ▷ the backrest of the vehicle is locked.
  - ▷ all heavy and sharp-edged parts in the vehicle are secured.
  - ▷ all people in the vehicle are secured.
  - ▷ you secure the child restraint with the three-point seat belt or the LATCH fastening system when it is not in use.
-

## Installation instructions

### Suitability

The Porsche Baby Seat LATCH is designed for use only by children whose weight is 29 lbs (13 Kg) or less and whose height is 31 inches (80 mm) or less.

**LATCH** = Lower Anchors and Tethers for children

### Approval and Testing

This child restraint system conforms to all applicable Federal Motor Vehicle Safety standards.

This child restraint is not certified for aircraft use.



### Information

Do not make any modifications to the Porsche Baby Seat LATCH and do not use any unsuitable accessories. Otherwise the warranty will be rendered invalid.

---

## How to use your Porsche Baby Seat LATCH

The Porsche Baby Seat LATCH may only be installed in the following seats in the vehicle:

In the direction of travel	no
Opposite the direction of travel	yes
Secured with two-point seat belt (lap belt)	yes
Secured with three-point seat belt	yes
Secured with via LATCH system	yes
On the front passenger seat	<sup>1)</sup> yes
On outer rear seats	yes
On centre rear seat	yes

<sup>1)</sup> Do not use this product on front passenger seat if the front-passenger airbag is active! Use the rear seat.

## The Porsche Baby Seat LATCH may be used in the listed vehicles

Refer to the vehicle Owner's Manual or your Porsche Dealer will provide information about your vehicle model.

### Securing with three-point seat belt

Vehicle type	as of Modelyear	Passenger seat	Rear seat		
			left	middle	right
Panamera	2009	<sup>1)</sup> yes	yes	—	yes
Cayenne	2003	<sup>1)</sup> yes	yes	yes	yes
Macan	2014	<sup>1)</sup> yes	yes	yes	yes
911	1998	<sup>1)</sup> yes	no	—	no
Boxster	1997	<sup>1)</sup> yes	—	—	—
Cayman	2006	<sup>1)</sup> yes	—	—	—

### Securing with the LATCH system

Vehicle type	as of Modelyear	Passenger seat	Rear seat		
			left	middle	right
Panamera	2009	—	yes	—	yes
Cayenne	2003	—	yes	no	yes
Macan	2014	—	yes	no	yes
911	1998	<sup>1)</sup> yes	—	—	—
Boxster	1997	<sup>1)</sup> yes	—	—	—
Cayman	2006	<sup>1)</sup> yes	—	—	—

<sup>1)</sup> Never install this child restraint in the front passenger seat of a vehicle that has a passenger airbag, unless the airbag is switched off. When possible, it is strongly recommended that all child restraints be placed in the rear of the vehicle.

## Securing your child in place

### **⚠ WARNING**

Danger of severe or mortal injuries if the following instructions are not followed.

- ▷ Always secure your baby in the child restraint.
- ▷ Never leave your baby out of your sight when you place him or her on a raised surface (e.g. changing table, tabletop...).
- ▷ Take your child out of the child restraint as often as possible to take the pressure of his/her column. To do so, take frequent breaks from driving when on lengthier trips. When you are outside of the vehicle, do not leave your child in the child restraint for too long.

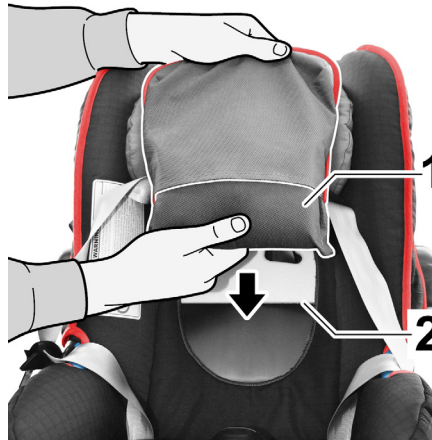

### Removing the Support Cushion

The support cushion (1) improves the ergonomic properties for your baby.

You can use the support cushion until your baby is large enough that you have to adjust the headrest (2) height out of the bottom position.

1. Take the support cushion (1) out of the pocket in the headrest cover.

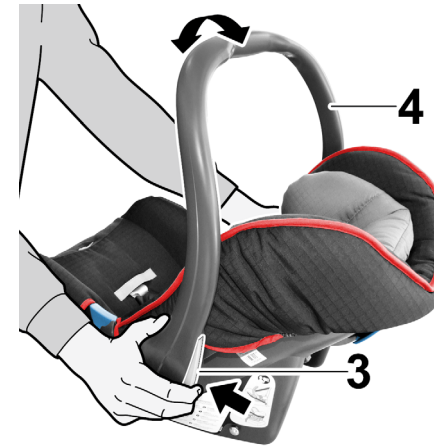

### Adjusting the Carrying Handle

You can engage the carrying handle in three positions:

1. Simultaneously press both buttons (3) on the carrying handle (4).
2. With the buttons (3) pressed, swivel the carrying handle (4) forward or back until the carrying handle engages in the desired position.

**⚠ WARNING** Carrying Handle

Danger of severe or mortal injuries if the carrying handle is not properly engaged.

- ▷ Check whether the carrying handle is engaged by holding the child restraint and moving the carrying handle back and forth.
- 



**Position A**

Carrying and transport in the vehicle



**Position B**

Laying down and buckling in your baby

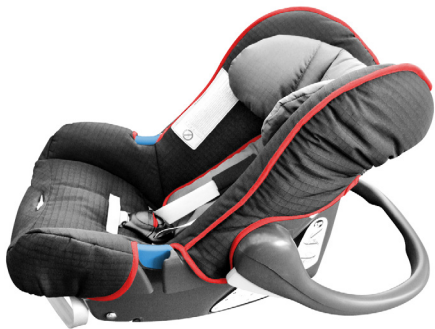

### Position C

Secure stand outside the vehicle



### Adapting the Headrest

**A properly adapted headrest provides ideal support for your baby in the child restraint.**

The headrest (2) must be adjusted so that the shoulder belts (5) are at or slightly below the shoulder height of your baby.

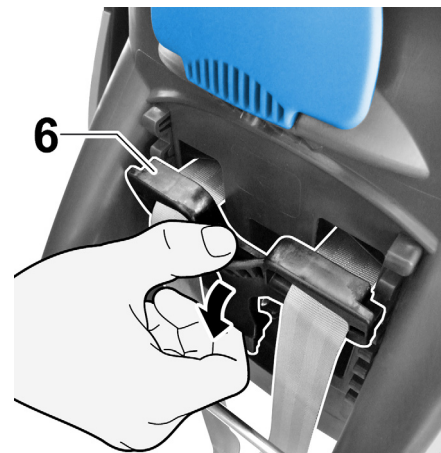

### Adjusting the Headrest

1. Open the buckle.
2. Tilt the headrest adjuster (6) out of the lock.



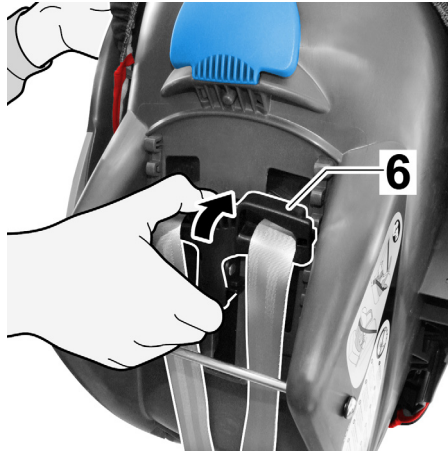

3. Push the headrest adjuster (6) to the correct belt height and engage the headrest adjuster.

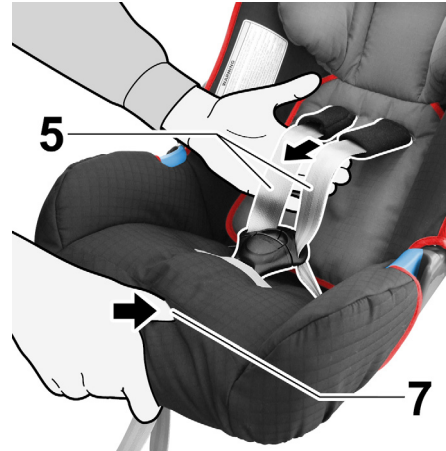

### Loosening the shoulder belts

1. Press the adjusting button (7) and simultaneously pull the two shoulder belts (5) forward.



### Buckling in your Baby

1. Loosen the shoulder belts (refer to section „Loosening the shoulder belts“).
2. Open the buckle (8) (press the red button).
3. Put your baby into the child restraint.

**CAUTION** Twisted or Interchanged Shoulder Belts

Twisted or interchanged shoulder belts can severely injure your child.

▷ Do not twist or interchange the shoulder belts.

4. Guide the shoulder belts (5) over your baby's shoulders.

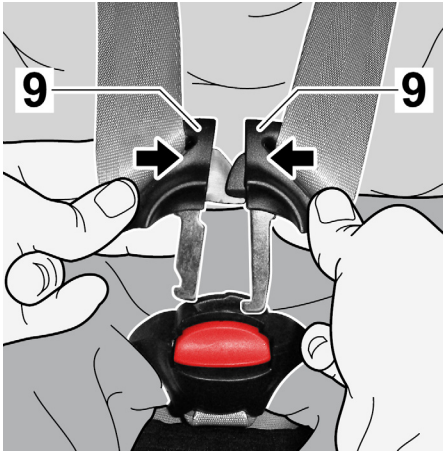

5. Bring the belt tongues (9) together

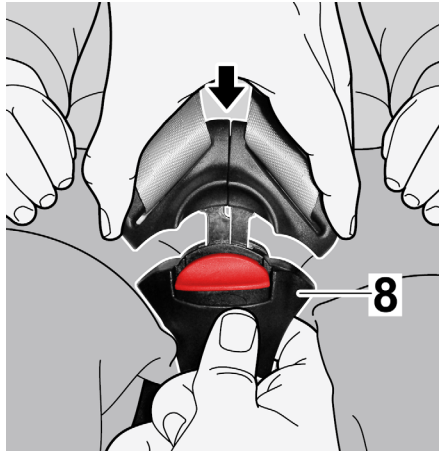

6. and insert the belt tongues into the buckle (8) until you hear them engage. **CLICK!**

**⚠ WARNING** Improper Child Restraint Use

- Risk of injury if your child is buckled in improperly.
- ▷ Make sure that the belt tongues are properly engaged in the buckle.
  - ▷ Make sure that the shoulder belts fit snugly.
  - ▷ Make sure that the shoulder belts are not too tight against the neck.
-

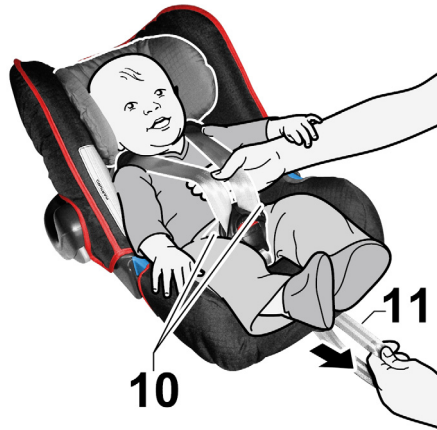

7. Pull the end of the belt **(11)** until the shoulder belts are snug against your baby's body.

**i** **Information**

The lap belts **(10)** must pass as low as possible over your child's hips.

**⚠ WARNING** End of Belt

Risk of injury if the following instructions are not followed.

- ▷ Never trap the end of the belt in moving parts (e.g. automatic doors, escalators...).



**Securing your Child properly**

Danger of severe or mortal injuries if your child is buckled in improperly.

In the interests of your child's safety, check that...

- the shoulder belts of the child restraint are snug against the body without constricting the baby.
- the shoulder belts **(5)** are correctly adjusted.
- the shoulder belts are not twisted.
- the belt tongues **(9)** are correctly engaged in the buckle **(8)**.
- the head restraint has been correctly adjusted.

## Fastening in the vehicle

### **WARNING**

Improper Child Restraint Use

Danger of severe or mortal injuries if the child seat is not installed properly

- ▷ The entire base of the child restraint must always be resting directly on the seat cushion surface of the vehicle seat.
- ▷ Never place anything underneath the child restraint (e.g. blankets/covers).



### Fastening the child restraint with LATCH System

1. Take the LATCH belt (12) out the net (14).
2. Position the child restraint onto the rear seat against the direction of travel (baby faces to the rear).



#### Information

If the child restraint is too unstable or not flat on the seat, select a different seat.

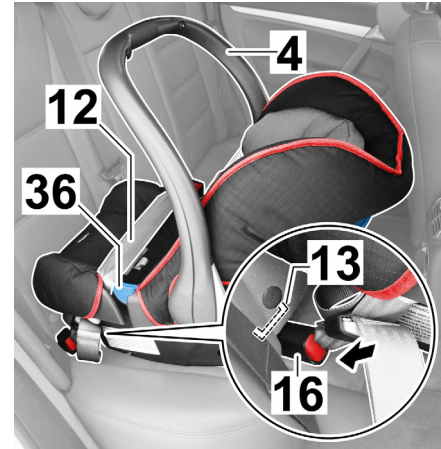

3. Make sure that the carrying handle (4) is in the top position A (refer to section "Adjusting the carrying handle").
4. Press the right-hand LATCH belt buckle (when looking in the direction of travel) (16) onto the LATCH bar (13) of the seat so that it engages audibly. **CLICK!**
5. Insert the LATCH belt (12) into the pale blue seat belt guides (36) on both sides of the child restraint.



#### Information

Do not twist the belt

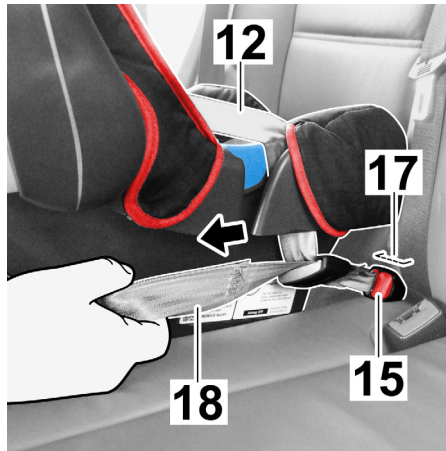

6. Press the left-hand LATCH belt buckle (15) onto the left LATCH bar (17) of the seat so that it also engages audibly.
7. Firmly press the child restraint against the seat backrest, and tighten the LATCH belt (12) by pulling the loose ends of the belt (18) on both sides of the child restraint.

### Installing your child restraint correctly

**⚠ DANGER** Incorrectly Installed Child Restraint

An incorrectly installed child restraint cannot protect the child as intended in the event of an accident, sharp braking maneuvers or sudden changes of direction and may lead to serious or fatal injuries to the child or other vehicles occupants.

In the interest of your child's safety, make sure that:

- ▷ the child restraint is secured in a rear-facing position opposite the vehicle's forward direction of travel.
- ▷ the child restraint is only installed on the front-passenger seat as long as no front airbag can deploy in the direction of the child restraint.
- ▷ the child restraint is secured with the **LATCH belt**.

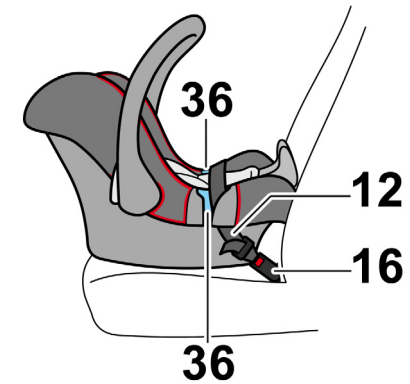

- ▷ the Latch belt (12) passes through the two pale blue seat guides (36) on the edges of the child restraint.
- ▷ both LATCH belt buckles (16) and (15) properly engage in the LATCH bars of the seat.

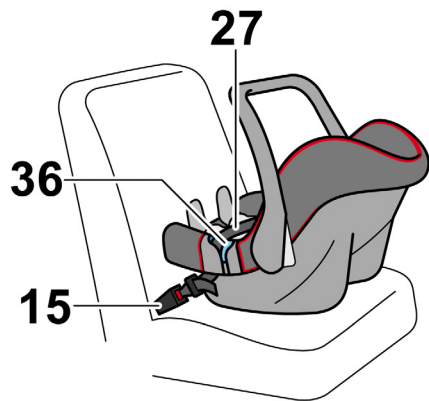

▷ the LATCH belt (27) is pulled taut and not twisted.

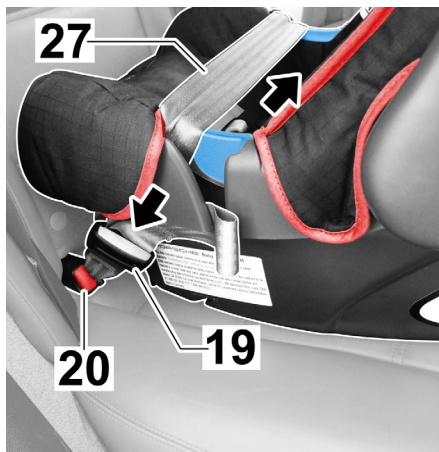

### Remove the child restraint with LATCH System

1. Press the button (19) on both tension buckles of the LATCH belt (27) and loosen the belt.
2. Press the red button (20) on the left and right LATCH belt buckle, and release the LATCH belt from the LATCH bars.
3. Store the LATCH belt in the net, and take the child restraint out of the vehicle.

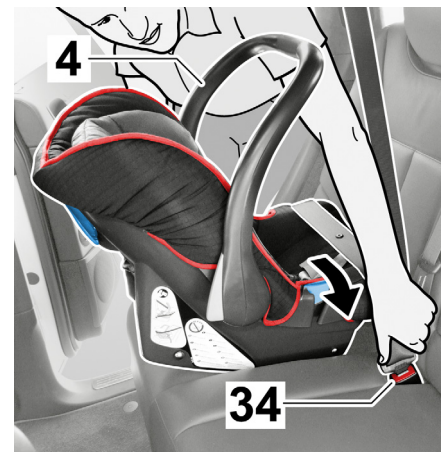

### Fastening the child restraint with the Three-Point Seat Belt

1. Position the child restraint onto the rear seat against the direction of travel (baby faces to the rear).

#### **i** Information

If the child restraint is too unstable or not flat on the seat, select a different seat.

2. Make sure that the carrying handle (4) is in position A (refer to section "Adjusting the Carrying Handle")
3. Pull the vehicle's three-point seat belt out and guide it over the child restraint.
4. Insert the belt tongue into the buckle (34).



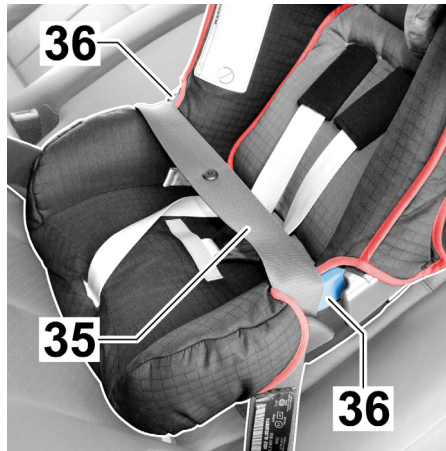

5. Lay the lap belt (35) into the pale blue belt guides (36) on both sides of the child restraint edge.



6. Pull the diagonal belt (37) behind the top end of the child restraint.

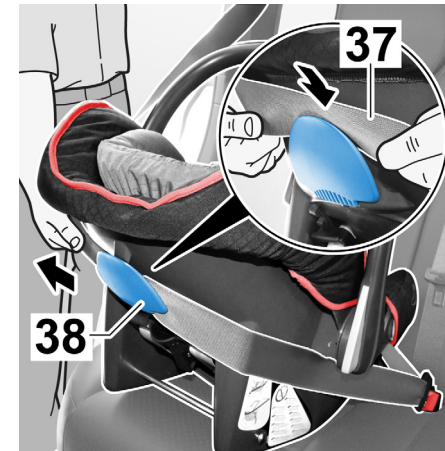

7. Push the diagonal belt (37) between the dark blue holder (38) and the child restraint until the belt engages.

**i** Information

Do not twist the three-point seat belt.

8. Tighten the diagonal belt.

## Installing your child restraint correctly

**DANGER**

Incorrectly Installed  
Child Restraint

An incorrectly installed child restraint cannot protect the child as intended in the event of an accident, sharp braking maneuvers or sudden changes of direction and may lead to serious or fatal injuries to the child or other vehicles occupants.

In the interest of your child's safety, make sure that:

- ▷ the child restraint is secured in a rear-facing position opposite the vehicle's forward direction of travel.
- ▷ the child restraint is only installed on the front-passenger seat as long as no front airbag can deploy in the direction of the child restraint.
- ▷ the child restraint is secured with a lap-shoulder belt as indicated in this operation instruction.

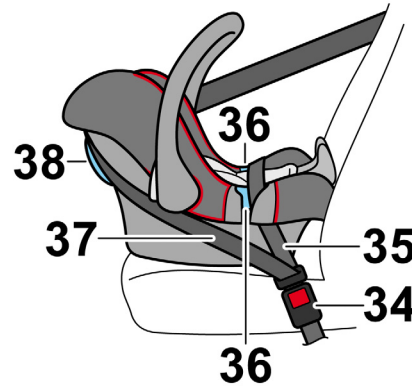

- ▷ the lap belt (35) passes through the two pale blue belt guides (36) at the edge of the child restraint.
- ▷ the diagonal belt (37) passes between the dark blue holder (38) and the child restraint.
- ▷ the three-point seat belt is pulled taut and not twisted.

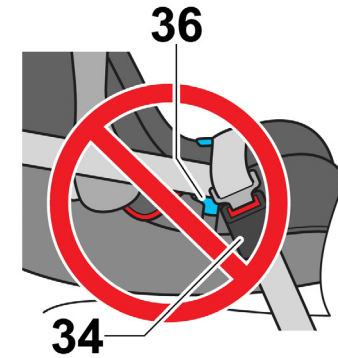

- ▷ The buckle (34) must not lie in the light blue belt guide (36) or be positioned so far forward that it lies in front of (in the direction of travel) the pale blue belt guide (36).



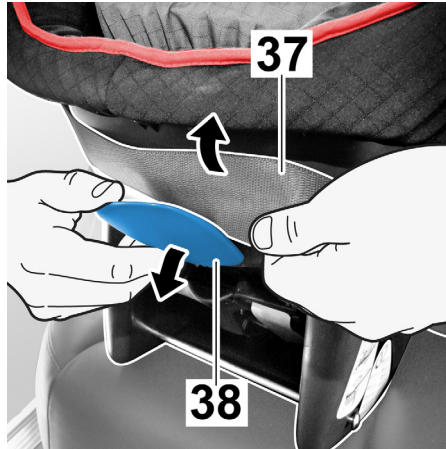

### Removing the child restraint with the Three-Point Seat Belt

1. Push the dark blue holder (38) slightly away from the child restraint to disengage the diagonal belt (37).

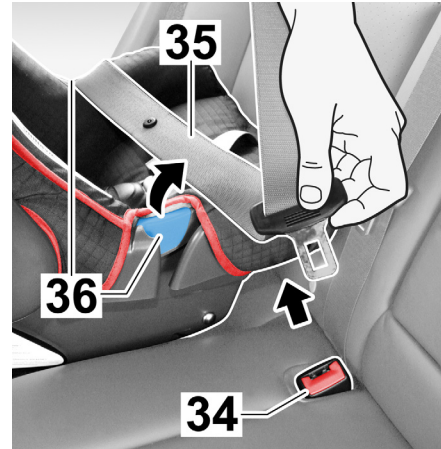

2. Open the buckle (34) and take the lap belt (35) out of the pale blue belt guides (36).
3. Return the three-point seat belt (35) to its original position.
4. Remove the child restraint.

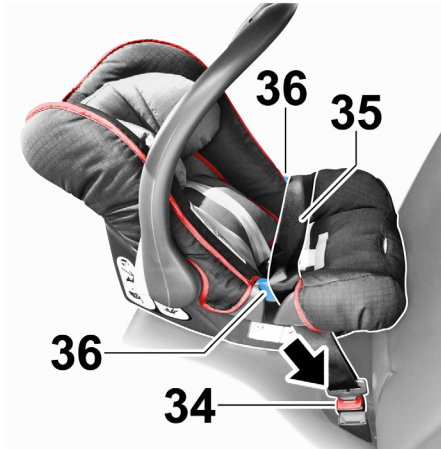

### Fastening the child restraint with a Lap Belt

5. Position the child restraint onto the rear seat against the direction of travel (baby faces to the rear).

#### **i** Information

If the child restraint is too unstable or not flat on the seat, select a different seat.

6. Make sure that the carrying handle is in position A (refer to section "Adjusting the Carrying Handle")
7. Take the lap belt (35) and guide it over the child restraint.
8. Insert the belt tongue into the buckle (34).

9. Lay the lap belt (35) into the pale blue belt guides (36) on both sides of the child restraint edge.
10. Tighten the lap belt.

### Installing your child restraint correctly

**⚠ DANGER** Incorrectly Installed Child Restraint

An incorrectly installed child restraint cannot protect the child as intended in the event of an accident, sharp braking maneuvers or sudden changes of direction and may lead to serious or fatal injuries to the child or other vehicles occupants.

- ▷ In the interest of your child's safety, make sure that:
  - ▷ the child restraint is secured in a rear-facing position opposite the vehicle's forward direction of travel
  - ▷ the child restraint is only installed on the front-passenger seat as long as no front airbag can deploy in the direction of the child restraint
  - ▷ the child restraint is secured with a lap belt.

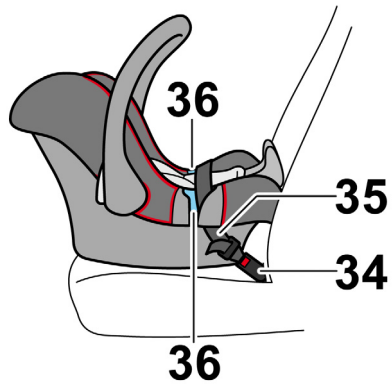

- ▷ the lap belt (35) passes through the two pale blue belt guides (36) at the edge of the child restraint.
- ▷ the lap belt is pulled taut and not twisted.



- ▷ The buckle (34) must not lie in the light blue belt guide (36) or be positioned so far forward that it lies in front of (in the direction of travel) the pale blue belt guide (36).

### Removing the child restraint with Lap Belt

1. Open the buckle (34) and take the lap belt (35) out of the pale blue belt guides (36).
2. Remove the child restraint.



### Fitting the Sun Shade

1. Adjust the carrying handle to position B (refer to section "Adjusting the carrying handle").
2. Engage the rubber loops (23) of the sun shade into the hooks on the carrying handle from below.

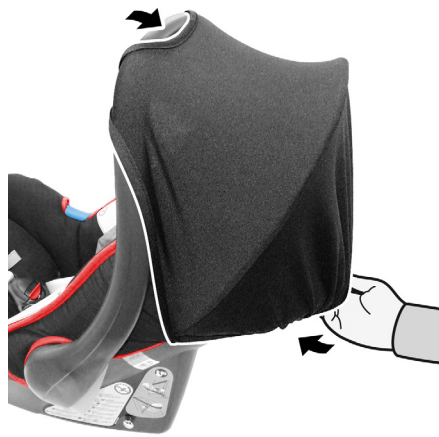

3. Pull the elastic seam over the upper edge of child restraint.

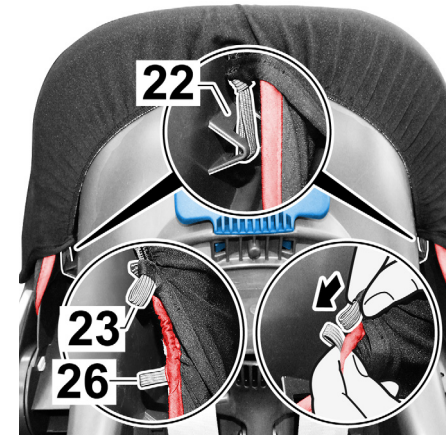

4. Guide the rubber loops (23) of the sun shade through the rubber loops of the seat shell cover (26) and engage the rubber loops of the sun shade in the hooks (22) under the edge of the child restraint.

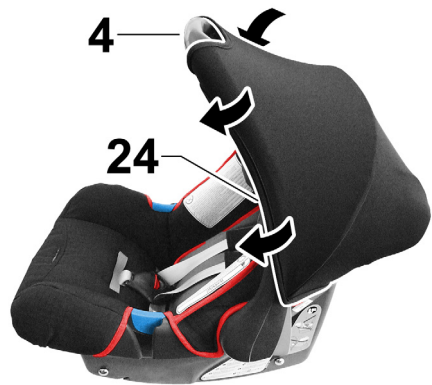

5. Tighten the sun shade by pulling the edge of the hood (24) over the carrying handle (4) and moving the handle to position.

## Cleaning

### DANGER

Using Damage Child Seat

Danger of severe injuries if you abruptly change the direction of travel, brake heavily or have an accident.

- ▷ A damaged seat cover must be replaced.
- ▷ The child seat must be replaced if it was damaged or was stressed in an accident.
- ▷ The child seat must not be used without a cover. Make sure to use only a genuine cover, because the cover is an essential part of the system function.

### NOTICE

Risk of damage due to improper cleaning.

- ▷ Please observe the instructions on the cover's laundry label. If the cover is washed at a temperature higher than 30°C (86°F), the cover fabric may bleed.
- ▷ Do not spin-dry the cover and **never** dry it in an electric dryer (the fabric could separate from the cushion).
- ▷ You can clean the **plastic parts** and **belts** with a soap solution. **Do not** use any aggressive agents (e.g. solvents).

You can remove the **cover** and machine-wash it with mild detergent at 30°C (86°F) in the gentle cycle.

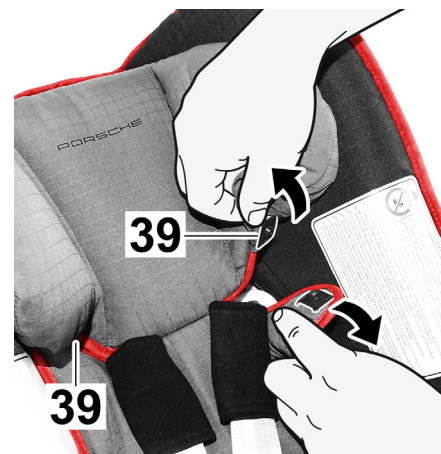

## Removing the Cover

1. Loosen the belts as much as possible (refer to section "Buckling in your Baby").
2. Open the buckle.
3. Move the headrest to the lowermost position (refer to section "Adjusting the Headrest").
4. Open the snap fasteners (39) on the left and right sides of the headrest cover.

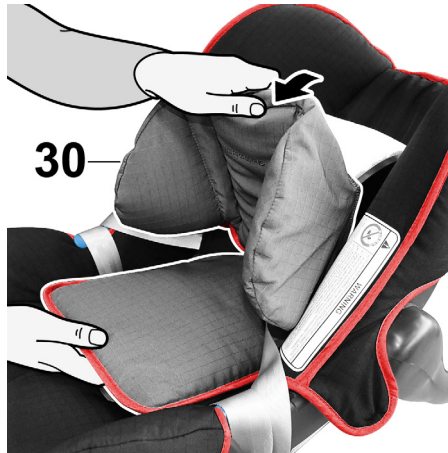

5. Remove the headrest cover (30).

**i Information**

Do not damage the styrofoam insert when pulling off the headrest cover.

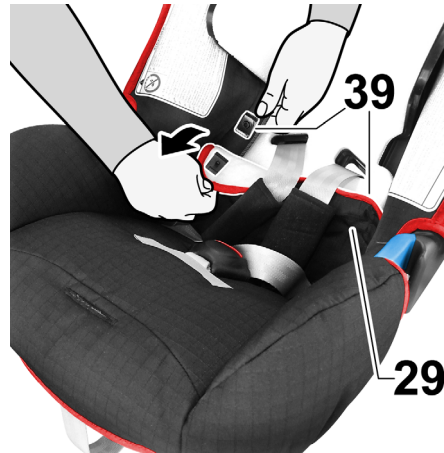

6. Open the snap fasteners (39) on the left and right sides of the seat shell cover.
7. Fold the back part (29) of the seat shell cover onto the seat surface.
8. Thread the belts out through the opening in the seat shell cover.

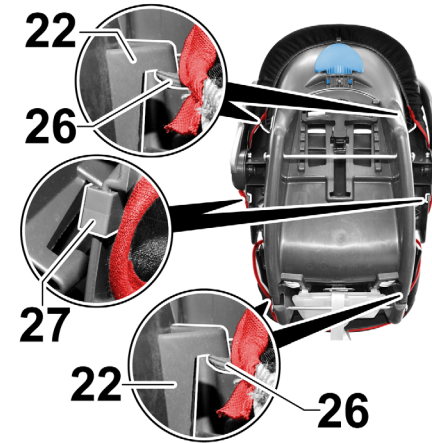

9. Disengage the rubber loops (26) of the seat shell cover from the hooks (22) below the edge of the child restraint.
10. Disengage the clips (27) from the edge of the child restraint.



**11.** Thread the buckle (8) out of the seat shell cover.



**12.** Pull the seat shell cover upward slightly and pull the seat shell cover off over the headrest.

## Fitting the Cover

**CAUTION** Twisted or Interchanged Shoulder Belts

Twisted or interchanged shoulder belts can severely injure your child.

▷ Do not twist or interchange the shoulder belts.

**1.** Fit the cover in the reverse order.



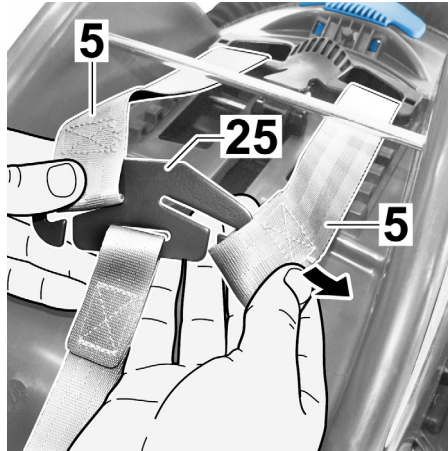

### Removing the Belts

1. Pull the cover off (refer to section "Removing the Cover").
2. Disengage the shoulder belts (5) from the connecting piece (25).

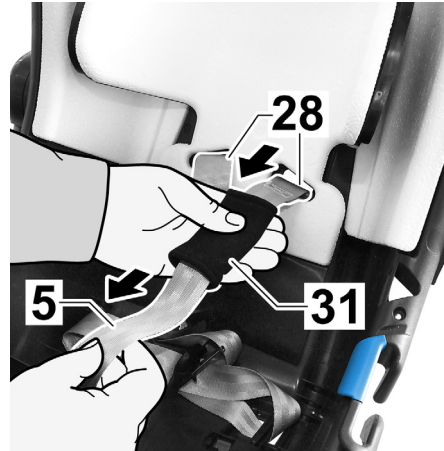

3. Pull the shoulder belts (5) out of the belt slots (28) and the shoulder pads (31).



4. Pull out the metal plate (32) with which the shoulder belt (5) is fastened at the bottom of the child restraint.

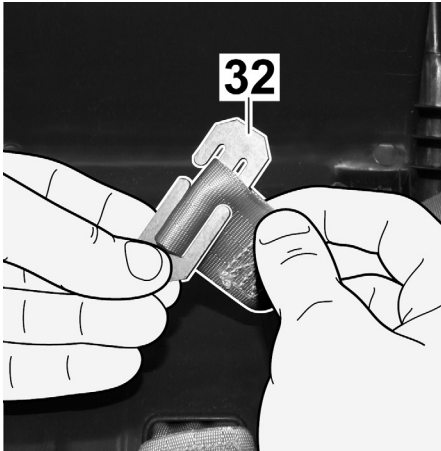

5. Push the belt loops back on the short side of the metal plate (32) and disengage the belt loops.
6. You can now pull the belts out of the child restraint.

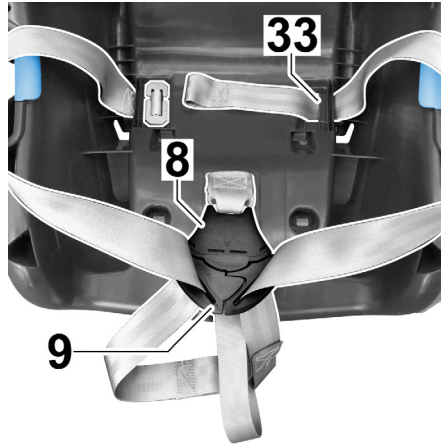

### Installing the Belts

1. Insert the belt tongues (9) into the buckle (8).

**⚠ CAUTION** Twisted or Interchanged Belts

Twisted or interchanged belts can severely injure your child.

▷ Do not twist or interchange the belts.

2. Thread the belt loop through the outer side slot of the child restraint first and then through the inner side slot (33).



3. Engage the metal plate (32) in the long belt loop (engage the long side of the metal part first, then the short side)



4. Pull on the belt until the metal plate (32) lies straight in the opening of the seat shell.
5. Open the buckle again.

**⚠ DANGER** Damaged Belt Straps

Damaged belt straps can tear in an accident and severely injure your child.

- ▷ Do not use any sharp or pointed objects when threading in the belts.

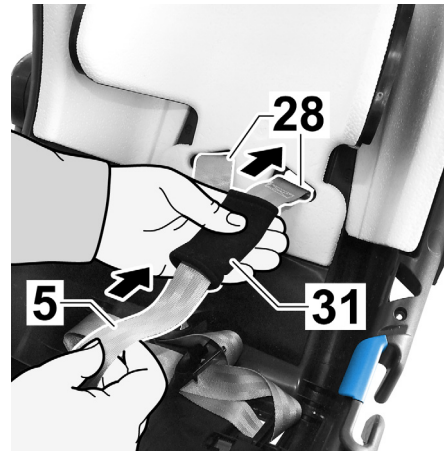

6. Thread the shoulder belts (5) through the shoulder pads (31) and the belt slots (28).

**⚠ CAUTION** Twisted or Interchanged Shoulder Belts

Twisted or interchanged shoulder belts can severely injure your child.

- ▷ Do not twist or interchange the shoulder belts.

7. Thread the shoulder belts (5) through the shoulder pads (31) and the belt slots (28).

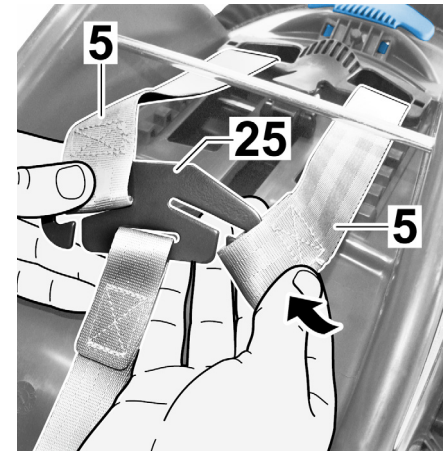

8. Engage the shoulder belts (5) in the connecting piece (25) again.
9. Fit the cover (refer to section "Fitting the Cover").

**⚠ DANGER** Safety Function

Loss of safety function.

- ▷ Regularly inspect all important parts for signs of damage. Make sure that the mechanical components function properly.
- ▷ Make sure that the child seat is not trapped between hard parts (vehicle door, seats rails, etc).
- ▷ The child seat must be replaced if it was damaged or was stressed in an accident.

## Care instructions for the belt buckle

Proper functioning of the buckle makes an important contribution to safety. Malfunctions of the buckle are mostly due to contamination.

### Malfunction:

- The belt tongues are ejected slowly when the red button is pressed.
- The belt tongues no longer lock into place and are ejected again.
- The belt tongues engage without a clearly audible "click".
- The belt tongues encounter resistance when being inserted.
- The belt tongue can only be opened with a great deal of force.

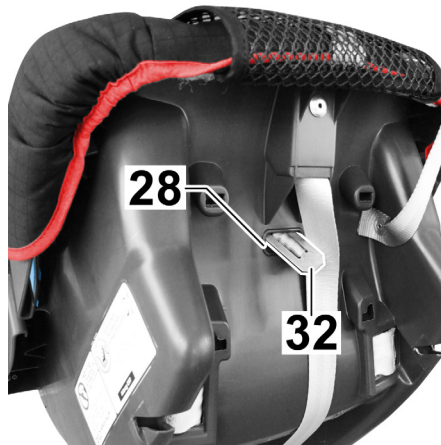

### Remedy:

This is how to wash out the buckle to make it function properly again.

1. Loosen the belts (refer to section "Buckling in your baby", step 1).
2. Tilt the child restraint backward; take the LATCH belt out of the net
3. Unhook the lower end of the net and fold it up.
4. Push the metal plate (32) with which the buckle is fastened to the seat shell upright through the belt slot (28).
5. Soak the buckle in warm water with detergent for at least one hour. Then rinse it out and allow it to dry thoroughly.

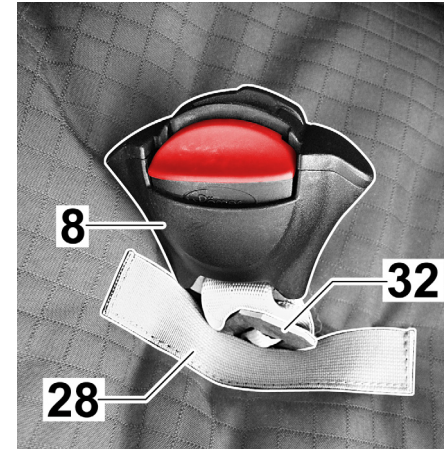

6. Push the metal plate (32) in upright position through belt slot (28) in the cover from top to bottom and through the seat shell. Firmly pull on the buckle (8) to check its attachment.
7. Fold the net down and hook it into both openings.

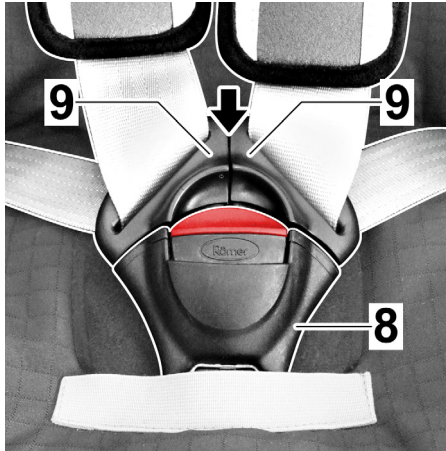

**Malfunction:**

- The belt tongues (9) can no longer be inserted into the buckle (8).

**Remedy:**

- Press the red button to release the buckle (8).

**Care instructions for the LATCH belt buckles**

The LATCH buckles must function properly for the the child restraint to provide protection to your child.

**Malfunction:**

- The LATCH belt buckles no longer engage onto the LATCH bars.
- The LATCH belt buckles do not engage with an audible „CLICK“.
- The LATCH belt buckles can only be opened with a great deal of force.

**Remedy:**

- Have the LATCH belt buckles checked by an authorized Porsche Dealer, and replaced if necessary.





PORSCHE

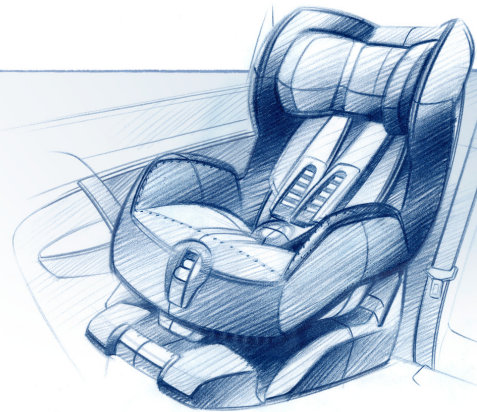

## **Operating Instructions Porsche Junior Seat LATCH G1**

**Thank you for purchasing your new Porsche Junior Seat LATCH. How to use and take care of your child restraint plays an important role in the child's safety. Please take the time to read these operating instructions carefully and keep them with the child restraint.**

These operating instructions provide you with important information on how to safely install and use the child restraint.



**Porsche Junior Seat LATCH**



# Content

## Safety Information

Safety Information.....	44
-------------------------	----

## Installation instructions

Installation instructions .....	46
How to use your Porsche Junior Seat LATCH .....	46
The Porsche Junior Seat LATCH may be used in the listed vehicles .....	47
Installing the Child Seat with LATCH Fastening System .....	48
Removing the Child Seat with LATCH Fastening System .....	50
Correct Installation of the Child Seat with LATCH Fastening System .....	50
Installing the Child Seat with LATCH Fastening System and top tether .....	51
Removing the Child Seat with LATCH Fastening System and top tether .....	54
Correct Installation of the Child Seat with LATCH Fastening System and top tether .....	55
Installing the Child Seat with Three-Point Seat Belt.....	56
Removing the Child Seat with Three-Point Seat Belt .....	58
Correct Installation of the Child Seat with Three-Point Seat Belt .....	59
Installing the Child Seat with Lap Belt and top tether .....	60
Removing the Child Seat with Lap Belt and top tether .....	63
Correct Installation of the Child Seat with Lap Belt and top tether .....	64

Adapting the Headrest .....	65
Adjusting the Headrest .....	65
Buckling in your Child .....	66
Securing your Child properly .....	67
Idle Position of the Child Seat .....	68

## Cleaning and Maintenance

Cleaning .....	69
Removing and Fitting the Covers .....	69
Removing the Headrest Cover .....	70
Removing the Seat Cushion Cover .....	70
Fitting the Covers .....	72
Removing the Belts .....	72
Installing the Belts .....	74
Buckle Care .....	77

## Safety Information

### Child restraint on the front passenger seat

If you intend to use a child restraint on the front passenger seat please refer to the vehicle Owner's Manual chapter „Child restraint systems“.

If your vehicle is equipped with a passenger airbag off system please take note of the green „AIRBAG OFF“ symbol on your child restraint.



If your vehicle is **not** equipped with a passenger airbag off system please take note of the red, circle and slash „AIRBAG OFF“ symbol on your child restraint.



If in doubt please see your authorized Porsche dealer.

#### WARNING

Danger of severe injuries if you abruptly change the direction of travel, brake heavily or have an accident.

- ▷ The child restraint's protective function is only ensured when the child restraint is both installed and used properly.
- ▷ Therefore, be sure to precisely follow each individual step of the operating instructions. Comply with the warning notes and safety precautions as well as the corresponding sections in the vehicle Owner's Manual.

You should pay particular attention to the information on the safety belts, airbags and child restraint system.

#### WARNING

If the passenger front airbag is not switched off, only install the child safety seat in one of the rear seats that is suitable for this purpose.

- ▷ Please observe the chapter "Child restraint systems" in the vehicle Owner's Manual.
- ▷ If in doubt please see your authorized Porsche dealer.

#### WARNING

Deactivated passenger airbags do not provide any protection in an accident.

- ▷ Reactivate the passenger airbag after removing the child seat.

#### WARNING

Passenger airbags can cause severe or mortal injury to children when they are triggered.

- ▷ In all vehicles, it is impermissible to use the child seat on the front passenger seat without deactivating the passenger airbag.

#### WARNING

Danger of severe injuries if you abruptly change the direction of travel, brake heavily or have an accident.

- ▷ Make sure that the child restraint's shoulder belts and belt buckle fit snugly against the child's body and are not twisted.
- ▷ If you use the child seat on the rear seat, move the front seat as far forward as possible, so that the child does not come into contact with the front seat.
- ▷ Position the front seat backrest vertically.
- ▷ No modification may be made to child restraint, the safety belts or the fastening points.
- ▷ Since the cover represents an important part of the safety function, the child seat must not be used without the cover.

**⚠ CAUTION**

Hot Plastic Parts

Danger of burns by hot plastic parts on the child seat if the seat was exposed to the sun.

- ▷ Protect the child seat against exposure to intense sunlight.
- 

**NOTICE**

Damage of child restraint. The child restraint is designed for transporting children.

- ▷ Do not place any heavy or sharp-edged objects in or on the child restraint, even if it has been removed from the vehicle.
- 

**⚠ WARNING**

Unsecured persons or objects

Danger of severe or mortal injuries if there are unsecured persons or objects in the vehicle.

Make sure that

- ▷ the backrest of the vehicle is locked.
  - ▷ all heavy and sharp-edged parts in the vehicle are secured.
  - ▷ all people in the vehicle are secured.
  - ▷ you secure the child restraint with the three-point seat belt or the LATCH fastening system when it is not in use.
-

## Installation instructions

### Suitability

The Porsche Junior Seat LATCH is designed for use only by children who weigh between 20 - 40 pounds (9 - 18 Kg) and whose height is between 31 - 38 inches (80 - 97 cm).

**LATCH** = **L**ower **A**nchors and **T**ethers for **c**hildren

### Approval and Testing

This child restraint system conforms to all applicable Federal Motor Vehicle Safety standards.

This child restraint is not certified for aircraft use.



### Information

Do not make any modifications to the Porsche Baby Seat LATCH and do not use any unsuitable accessories. Otherwise the warranty will be rendered invalid.

---

## How to use your Porsche Junior Seat LATCH

The Porsche Junior Plus Seat LATCH may only be installed in the following seats in the vehicle:

In the direction of travel	yes
Opposite the direction of travel	no
Secured with two-point seat belt (lap belt)	<sup>1)</sup> yes
Secured with three-point seat belt	yes
Secured with via LATCH system	yes
On the front passenger seat	<sup>2)</sup> yes
On outer rear seats	yes
On centre rear seat	yes

<sup>1)</sup> Only in combination with top tether.

<sup>2)</sup> Do not use this product on front passenger seat if the front-passenger airbag is active! Use the rear seat.

## The Porsche Junior Seat LATCH may be used in the listed vehicles

Refer to the vehicle Owner's Manual or your Porsche Dealer will provide information about your vehicle model.

### Securing with three-point seat belt

Vehicle type	as of Modelyear	Passenger seat	Rear seat		
			left	middle	right
Panamera	2009	<sup>1)</sup> yes	yes	—	yes
Cayenne	2003	<sup>1)</sup> yes	yes	yes	yes
Macan	2014	<sup>1)</sup> yes	yes	yes	yes
911	1998	<sup>1)</sup> yes	yes	—	yes
Boxster	1997	<sup>1)</sup> yes	—	—	—
Cayman	2006	<sup>1)</sup> yes	—	—	—

### Securing with the LATCH Fastening System

Vehicle type	as of Modelyear	Passenger seat	Rear seat		
			left	middle	right
Panamera	2009	—	yes	—	yes
Cayenne	2003	—	yes	no	yes
Macan	2014	—	yes	no	yes
911	1998	<sup>1)</sup> yes	—	—	—
Boxster	1997	<sup>1)</sup> yes	—	—	—
Cayman	2006	<sup>1)</sup> yes	—	—	—

<sup>1)</sup> Never install this child restraint in the front passenger seat of a vehicle that has a passenger airbag, unless the airbag is switched off. When possible, it is strongly recommended that all child restraints be placed in the rear of the vehicle.

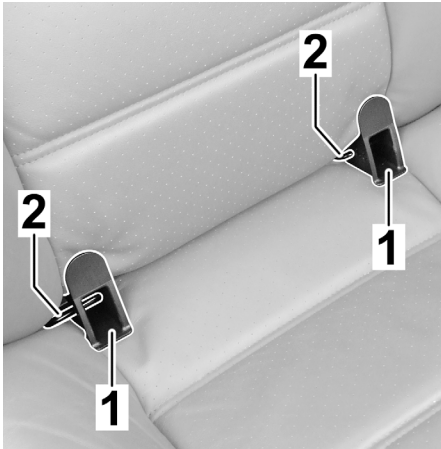

### Installing the Child Seat with LATCH Fastening System

1. If possible, clip the two insertion aids (1), with the opening facing up, onto the two LATCH fastening points (2).

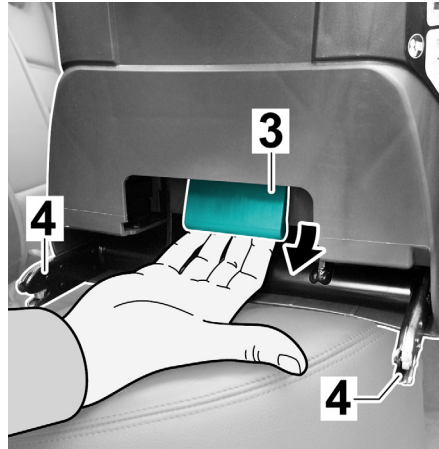

2. Use the green handle (3) to pull the locking arms (4) out to the lock.

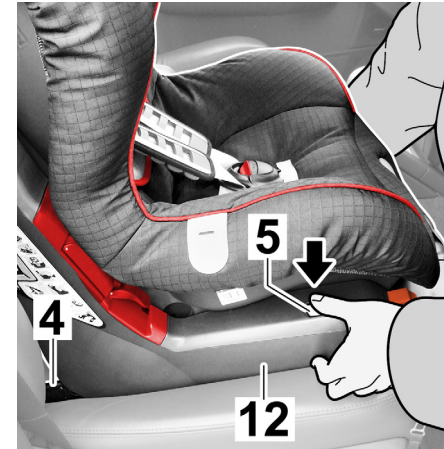

3. Press on the grey locking buttons (5) on the left and right sides of the seat lower section (12).

#### **i** Information

This ensures that both hooks of the locking arms (4) are open.



4. Push the two locking arms (4) into the insertion aids until the locking arms can be heard to engage on both sides.
5. Pull on the Porsche Junior Seat LATCH to make sure that it has engaged on both sides.

**⚠ DANGER**

**Looking Arms**

- Danger of severe or mortal injuries if the locking arms are not properly engaged.
- ▷ The green markings (7) must be visible on the locking buttons (5) on both sides.
  - ▷ Before every journey, make sure that the locking arms are correctly engaged.

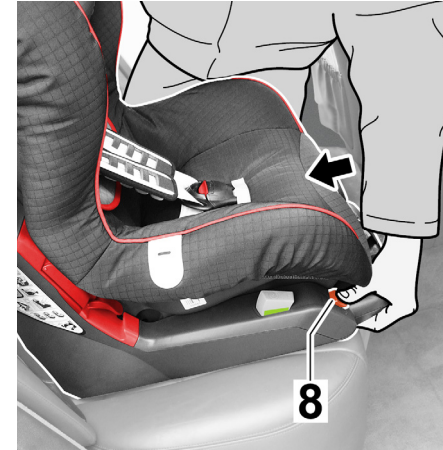

6. Press the orange tension button (8) and push the Porsche Junior Seat LATCH against the backrest of the vehicle.

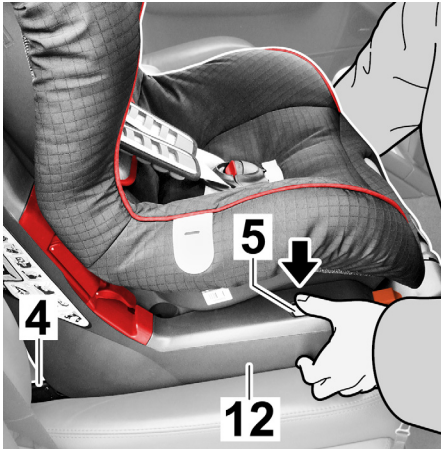

### Removing the Child Seat with LATCH Fastening System

1. Press on the grey locking buttons (5) on the left and right sides of the seat lower section (12). The locking arms (4) are released.

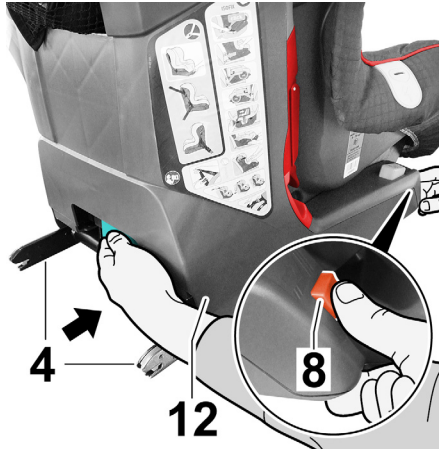

2. Press the orange tension button (8) and simultaneously push the locking arms (4) back into the seat lower section (12).
3. Remove the Porsche Junior Seat LATCH.

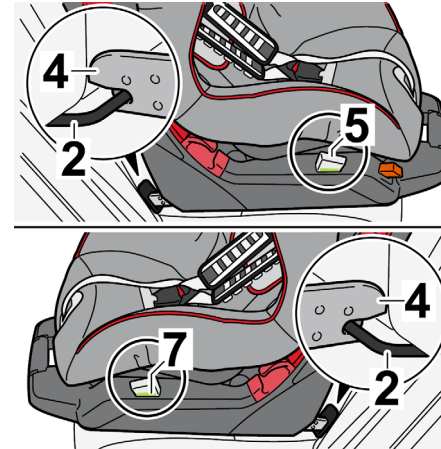

### Correct Installation of the Child Seat with LATCH Fastening System

**⚠ DANGER**

Incorrectly Installed Child Restraint

An incorrectly installed child restraint cannot protect the child as intended in the event of an accident, sharp braking maneuvers or sudden changes of direction and may lead to serious or fatal injuries to the child or other vehicles occupants. In the interest of your child's safety, check that:

- ▷ the Porsche Junior Seat LATCH is firmly engaged in the vehicle with the locking arms (4) in the LATCH fastening points (2) on both sides and that the green marking (7) is visible on both locking buttons (5).



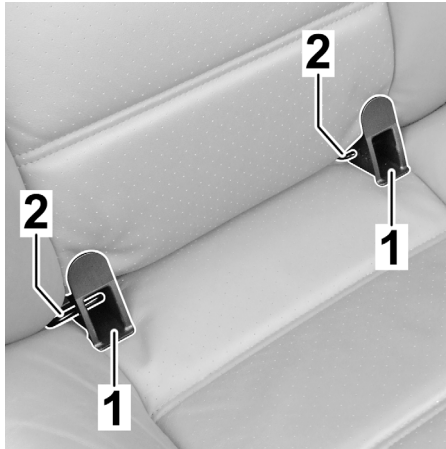

**Installing the Child Seat with LATCH Fastening System and top tether**

1. If possible, clip the two insertion aids (1), with the opening facing up, onto the two LATCH fastening points (2).

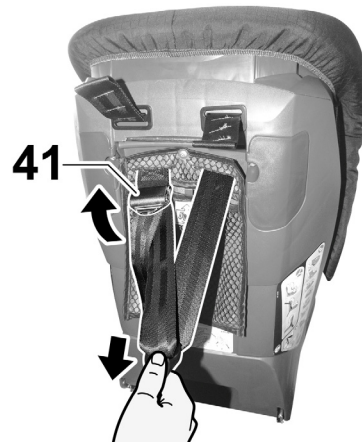

2. Take the top tether out of the cloth bag.
3. Lift the metal tongue (41) away from the strap and pull the strap out with the spring hook to a V-shape.



4. Place the Porsche Junior Seat LATCH on the rear vehicle seat in the direction of travel.



5. Guide the top tether right and left at (or run through) the headrest and place the top tether behind the vehicle seat.

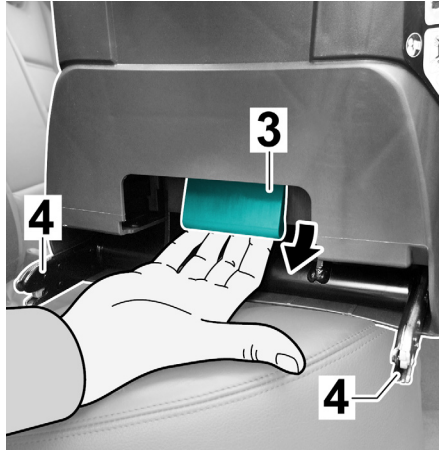

6. Use the green handle (3) to pull the locking arms (4) out to the lock.

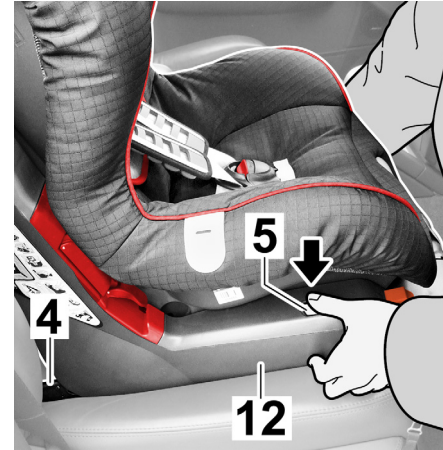

7. Press on the grey locking buttons (5) on the left and right sides of the seat lower section (12).

**i** Information

This ensures that both hooks of the locking arms (4) are open and ready to use.

**⚠ WARNING** Misuse Locking Arms

Danger of severe or mortal injuries if the locking arms are not properly engaged.

- ▷ The green markings (7) must be visible on the locking buttons (5) on both sides.
- ▷ Before every journey, make sure that the locking arms are correctly engaged.

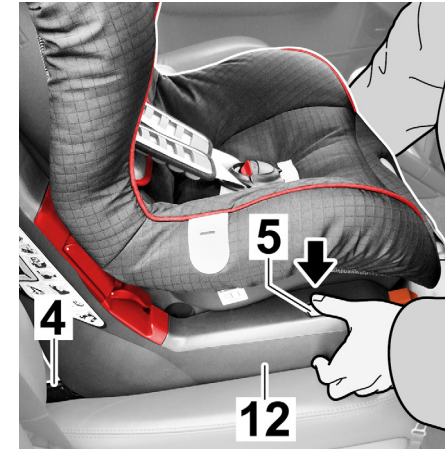

8. Push the two locking arms (4) into the insertion aids until the locking arms can be heard to engage on both sides.
9. Pull on the Porsche Junior Seat LATCH to make sure that it has engaged on both sides.

10. Press the orange tension button (8) and push the Porsche Junior Seat LATCH against the backrest of the vehicle.

**⚠ WARNING**

**Misuse Child Restraint Anchorages**

Child restraint anchorages are designed to withstand only those loads imposed by correctly fitted child restraints. Under no circumstances are they to be used for adults safety belts or harnesses. Such use could result in serious personal injury or death.

- ▷ Do not misuse the child restraint anchorages. Only attach **one** child seat top tether per anchorage.
- ▷ They are not designed to withstand loads imposed by adults.

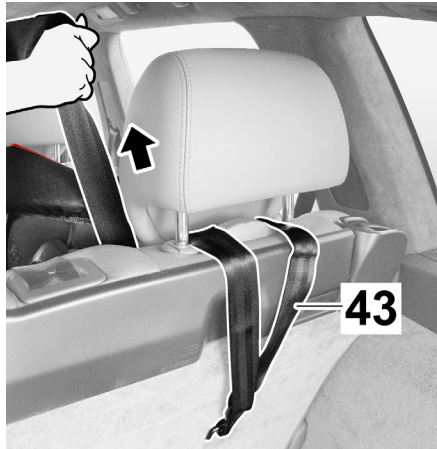

**11.** Hook the snap hook into the top tether anchoring point.

**i Information**

Use only top tether anchoring points, which are recommended in your vehicle Owner's Manual.

- 12.** Tighten the strap of the top tether (**43**) until lies against it tightly.

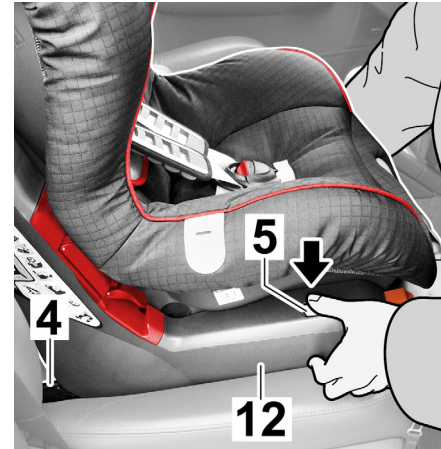

**Removing the Child Seat with LATCH Fastening System and top tether**

1. Press on the grey locking buttons (**5**) on the left and right sides of the seat lower section (**12**). The locking arms (**4**) are released.

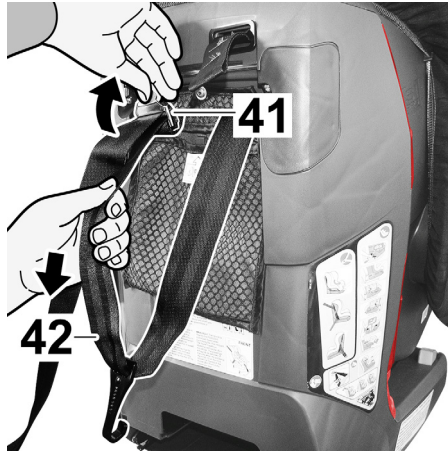

2. To release the top tether anchoring loosen the belt (42) by lifting the metall tongue (41) of the adjuster away from the belt.
3. Unhook the snap hook from the anchoring point.
4. Stow the top tether in the cloth bag.

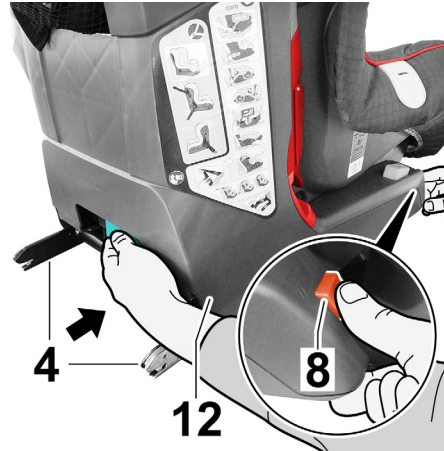

5. Press the orange tension button (8) and simultaneously push the locking arms (4) back into the seat lower section (12).
6. Remove the Porsche Junior Seat LATCH.

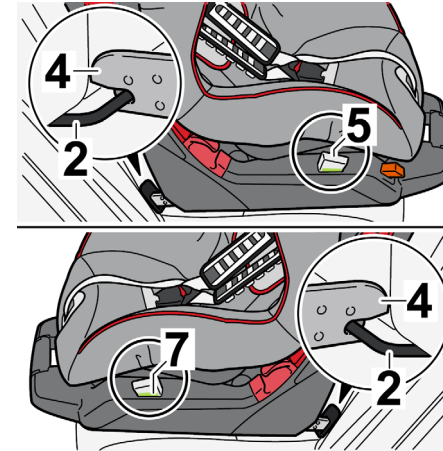

### Correct Installation of the Child Seat with LATCH Fastening System and top tether

**⚠ DANGER** Incorrectly Installed Child Restraint

An incorrectly installed child restraint cannot protect the child as intended in the event of an accident, sharp braking maneuvers or sudden changes of direction and may lead to serious or fatal injuries to the child or other vehicles occupants. In the interest of your child's safety, check that:

- ▷ the Porsche Junior Seat LATCH is firmly engaged in the vehicle with the locking arms (4) in the LATCH fastening points (2) on both sides and that the green marking (7) is visible on both locking buttons (5).
- ▷ the top tether is tightened over the backrest of the vehicle seat.





### Installing the Child Seat with Three-Point Seat Belt

1. Place the Porsche Junior Seat LATCH on the rear vehicle seat in the direction of travel.
2. Push the adjusting handle (10) up and pull the seat shell (11) forward to idle position.

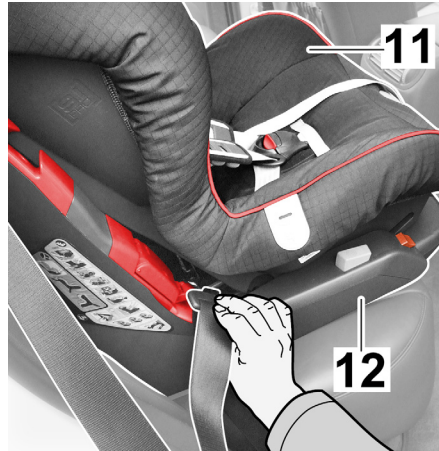

3. Pull the three-point seat belt out and guide it through between the seat shell (11) and the seat lower section (12).
4. Insert the belt tongue of the three-point seat belt into the vehicle buckle until it audibly clicks into place.

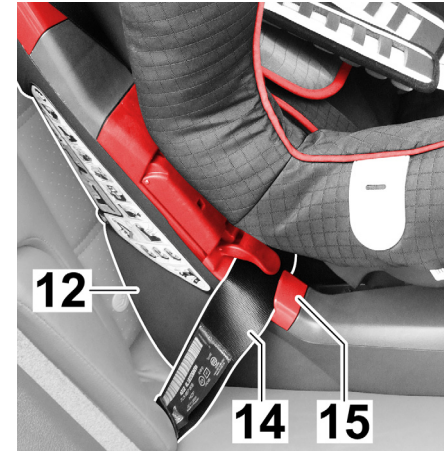

5. Lay the lap belt (14) into the light orange belt guides (15) on both sides of the seat lower section (12).

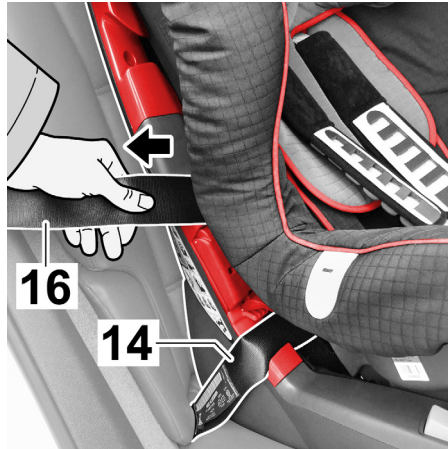

6. Tighten the lap belt (14) by pulling on the diagonal belt (16).

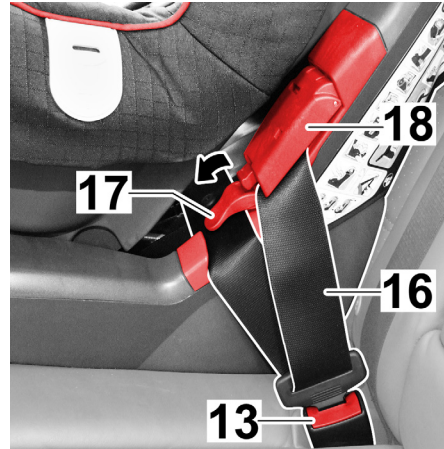

7. Swivel the clamping lever (17) of the dark red belt clamp (18) down on the side of the vehicle buckle (13).
8. Lay the diagonal belt (16) into the belt clamp.

**i** Information

Do not twist the diagonal belt.

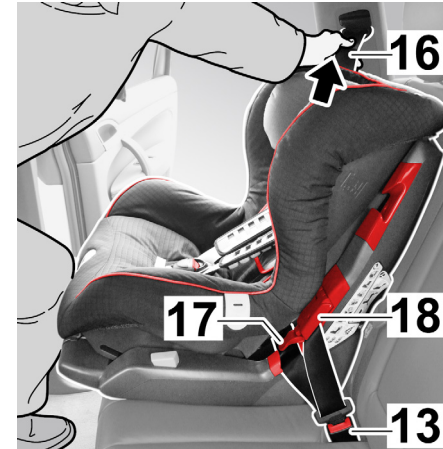

9. Use your knee to push the Porsche Junior Seat LATCH into the vehicle seat and simultaneously pull firmly on the diagonal belt (16).
10. Swivel the clamping lever (17) up until it engages.

**i** Information

The diagonal belt (16) must be clamped only with the belt clamp on the side of the vehicle buckle (13).

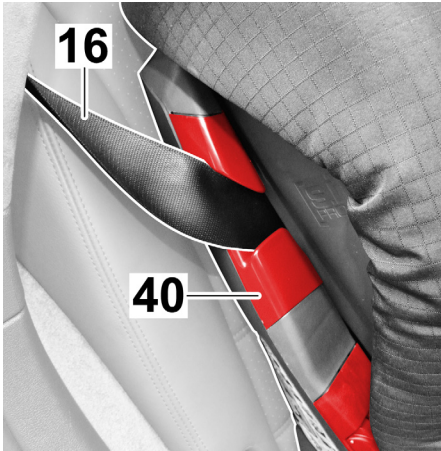

11. Lay the diagonal belt (16) into the dark red belt guide (40) on the other side.

**i** Information

Do not twist the diagonal belt.



12. Push the adjusting handle (10) up and push the seat shell (11) to the rear again.

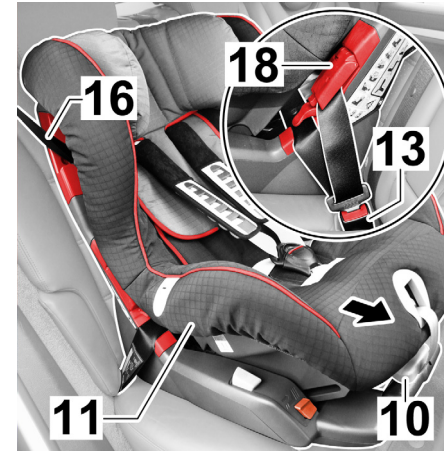

**Removing the Child Seat with Three-Point Seat Belt**

1. Push the adjusting handle (10) up and pull the seat shell (11) forward to idle position.
2. Open the vehicle buckle (13).
3. Now open the belt clamp (18) on the side of the vehicle buckle.
4. Take the three-point seat belt (16) out of the belt guides.
5. The Porsche Junior Seat LATCH can now be removed.





### Correct Installation of the Child Seat with Three-Point Seat Belt

**⚠ DANGER**

Incorrectly Installed Child Restraint

An incorrectly installed child restraint cannot protect the child as intended in the event of an accident, sharp braking maneuvers or sudden changes of direction and may lead to serious or fatal injuries to the child or other vehicles occupants. In the interest of your child's safety, check that:

- ▷ the Porsche Junior Seat LATCH is firmly installed in the vehicle.
- ▷ the three-point seat belt is taut and not twisted.
- ▷ Pull on the child seat to make sure that it has been installed securely.

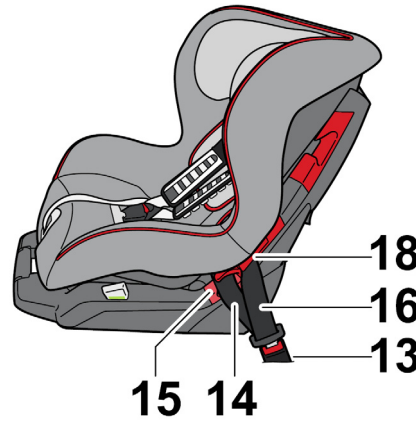

- ▷ the lap belt (14) passes through the two light red belt guides (15), the diagonal belt (16) is clamped only with the dark red belt clamp (18) on the side of the vehicle buckle (13).

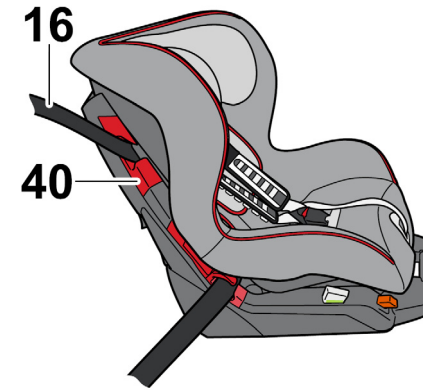

- ▷ the diagonal belt (16) passes through the dark red belt guide (40) on the opposite side of the vehicle buckle.

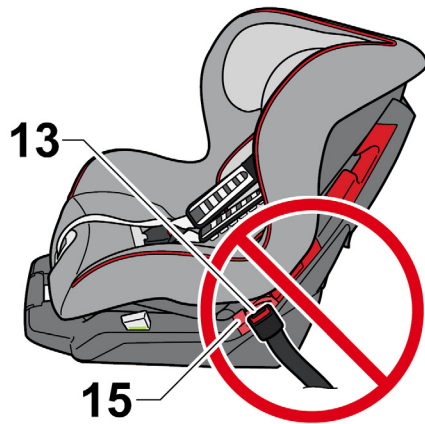

- ▷ the belt tongue and the vehicle buckle (13) of the three-point seat belt do **not** lie in the belt guide (15) of the Porsche Junior Seat LATCH.

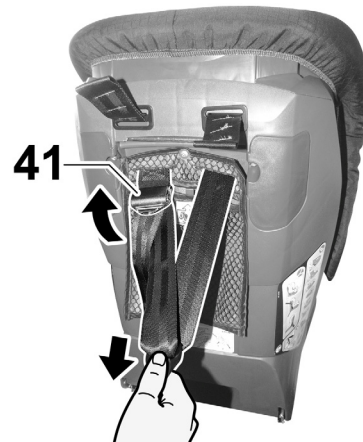

### Installing the Child Seat with Lap Belt and top tether

1. Take the top tether out of the cloth bag.
2. Lift the metal tongue (41) away from the strap and pull the strap out with the spring hook to a V-shape.
3. Place the Porsche Junior Seat LATCH on the rear vehicle seat in the direction of travel.

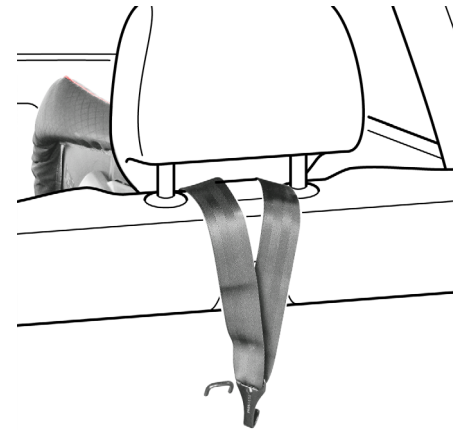

4. Guide the top tether right and left at (or run through) the headrest and place the top tether behind the vehicle seat.



5. Push the adjusting handle (10) up and pull the seat shell (11) forward to idle position.

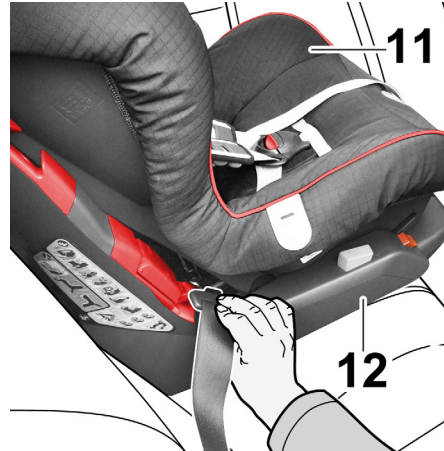

6. Take the lap belt and guide it through between the seat shell (11) and the seat lower section (12).

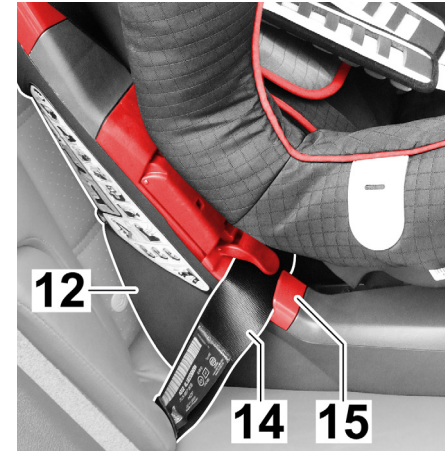

7. Lay the lap belt (14) into the light orange belt guides (15) on both sides of the seat lower section (12).

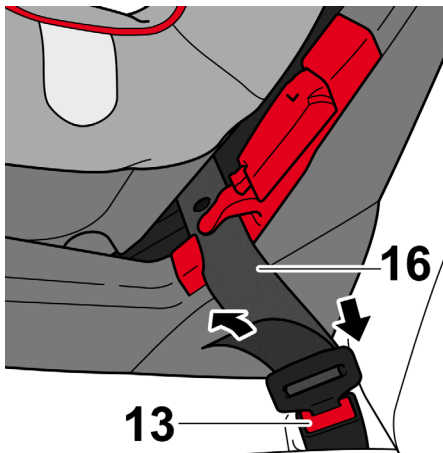

8. Insert the belt tongue of the lap belt (16) into the vehicle buckle (13) until it audibly clicks into place.

**i** Information

Do not twist the lap belt.

9. Tighten the lap belt.

**⚠ WARNING**

Misuse Child Restraint Anchorages

Child restraint anchorages are designed to withstand only those loads imposed by correctly fitted child restraints. Under no circumstances are they to be used for adults safety belts or harnesses. Such use could result in serious personal injury or death.

- ▷ Do not misuse the child restraint anchorages. Only attach **one** child seat top tether per anchorage.
- ▷ They are not designed to withstand loads imposed by adults.

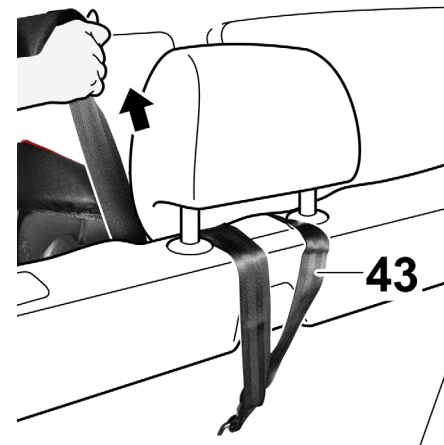

10. Hook the snap hook into the top tether anchoring point.

**i** Information

Use only top tether anchoring points, which are recommended in your vehicle Owner's Manual.

11. Tighten the strap of the top tether (43) until it lies against it tightly.

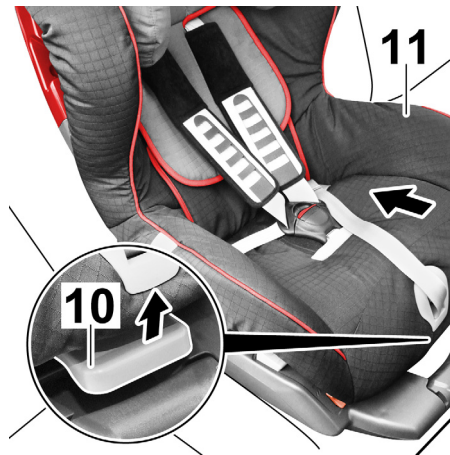

12. Push the adjusting handle (10) up and push the seat shell (11) to the rear again.

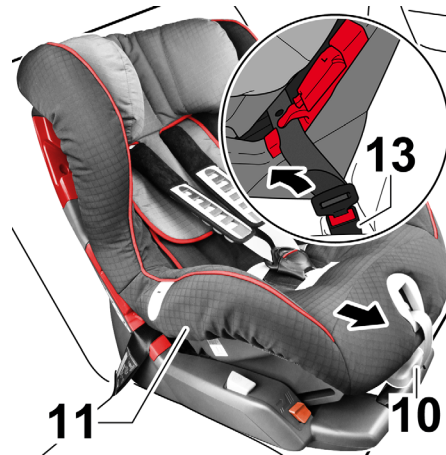

### Removing the Child Seat with Lap Belt and top tether

1. Push the adjusting handle (10) up and pull the seat shell (11) forward to idle position.
2. Open the vehicle buckle (13).
3. Take the lap belt out of the light orange belt guides.

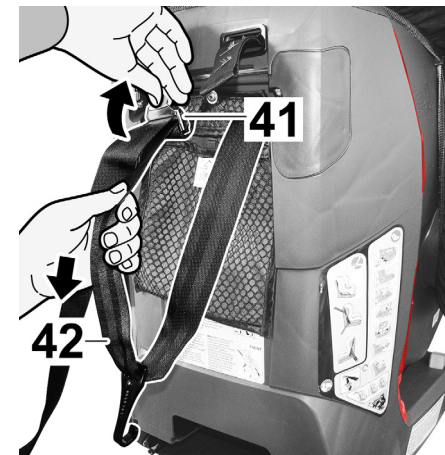

4. Unhook the snap hook from the anchoring point.
5. To release the top tether anchoring loosen the belt (42) by lifting the metal tongue (41) of the adjuster away from the belt.
6. Stow the top tether in the cloth bag.
7. The Porsche Junior Seat LATCH can now be removed.



### Correct Installation of the Child Seat with Lap Belt and top tether

**DANGER**

Incorrectly Installed Child Restraint

An incorrectly installed child restraint cannot protect the child as intended in the event of an accident, sharp braking maneuvers or sudden changes of direction and may lead to serious or fatal injuries to the child or other vehicles occupants. In the interest of your child's safety, check that:

- ▷ the Porsche Junior Seat LATCH is firmly installed in the vehicle.
- ▷ the lap belt is taut and not twisted.
- ▷ Pull on the child seat to make sure that it has been installed securely.
- ▷ the top tether is tightened over the backrest of the vehicle seat.



- ▷ the lap belt (14) passes through the two light red belt guides (15).

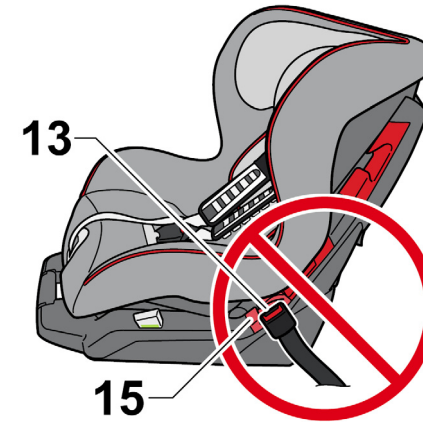

- ▷ the belt tongue and the vehicle buckle (13) of the lap belt do **not** lie in the belt guide (15) of the Porsche Junior Seat LATCH.



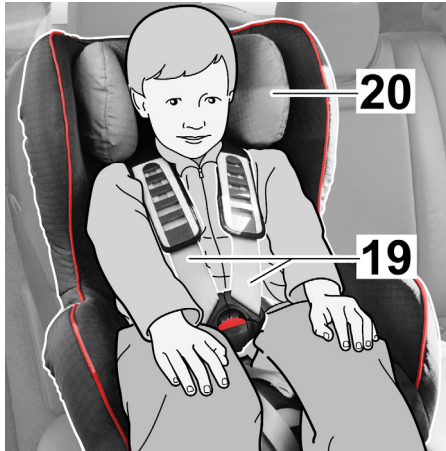

### Adapting the Headrest

A correctly adapted headrest (20) will provide optimum support for your child in the Porsche Junior Seat LATCH.

The headrest (20) must be adjusted so that the shoulder belts (19) are at or slightly above the shoulder height of your child.

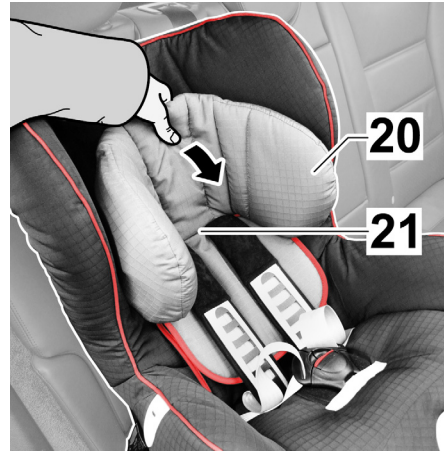

### Adjusting the Headrest

1. Loosen the belts as much as possible (refer to section "Buckling in your child" step 1)
2. Tilt the headrest (20) forward. The headrest adjuster (21) is now unlocked.

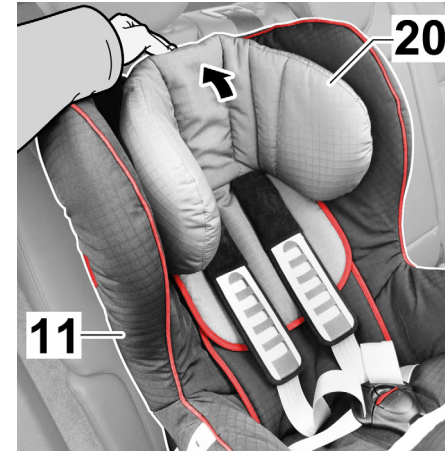

3. Move the headrest (20) to the correct shoulder belt height.
4. Fold the headrest (20) back to the seat shell (11) again to re-lock the headrest adjuster.

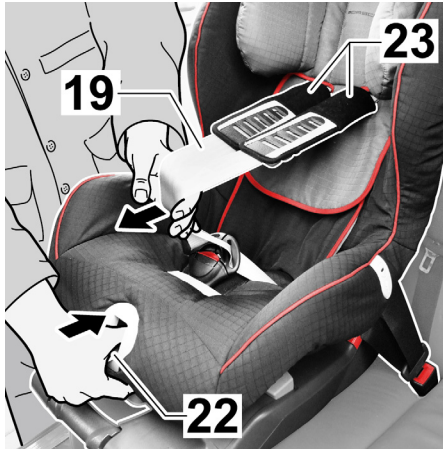

### Buckling in your Child

1. Press the adjusting button (22) and simultaneously pull the two shoulder belts (19) forward.

#### NOTICE

The shoulder pads could be damaged if they are pulled to loosen the shoulder belts.  
 ▷ Do not pull on the shoulder pads (23).

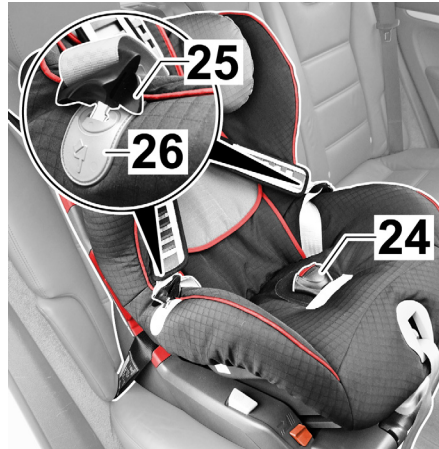

2. Open the buckle (24) by pressing the red button.
3. Insert the belt tongues (25) into the rubber retainers (26).
4. Put your child into the Porsche Junior Seat LATCH.
5. Disengage the belt tongues (25) again.

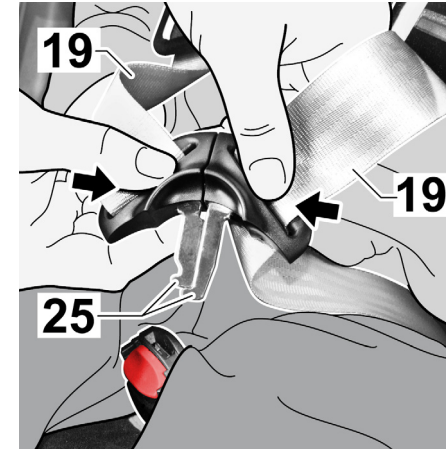

6. Guide the shoulder belts (19) over your child's shoulders.

#### ⚠ CAUTION Shoulder Belts

Danger of injury if the shoulder belts are twisted or interchanged.

- ▷ Do not twist or interchange the shoulder belts.

7. Bring the two belt tongues (25) together ...



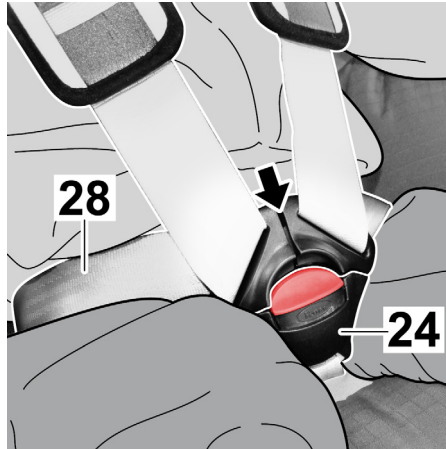

8. ... and insert the belt tongues into the buckle (24) until you can hear them engage. **CLICK!**

**CAUTION** Lap Belt Position

The lap belts can severely injure your child if they are positioned too high.

- ▷ The lap belts (28) must pass as low as possible over your child's groin.

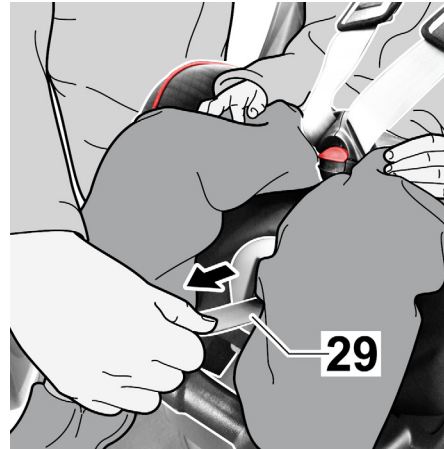

9. Tighten the belts until they are snug against the body. Pull the belt end (29) out straight to do this.

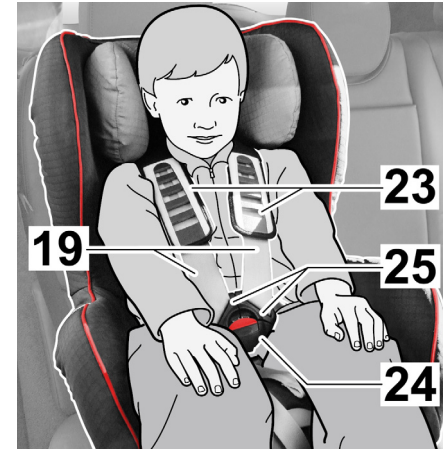

### Securing your Child properly

**DANGER** Incorrectly Installed Child Restraint

An incorrectly installed child restraint cannot protect the child as intended in the event of an accident, sharp braking maneuvers or sudden changes of direction and may lead to serious or fatal injuries to the child or other vehicles occupants. In the interest of your child's safety, check that:

- ▷ the belts of the Porsche Junior Seat LATCH are snug against the body without constricting your child.
- ▷ the shoulder belts (19) are correctly adjusted.
- ▷ the belts are not twisted.
- ▷ the belt tongues (25) are correctly engaged in the buckle (24).
- ▷ the shoulder pads (23) are resting properly on the body.



### Idle Position of the Child Seat

1. Push the adjusting handle (10) up and pull the seat shell forward to the desired position.

#### **i** Information

The seat shell (11) must firmly engage in every position. Pull on the seat shell to check whether it has engaged properly.

---

## Cleaning

### WARNING

Danger of severe injuries if you abruptly change the direction of travel, brake heavily or have an accident.

- ▷ A damaged seat cover must be replaced.
  - ▷ The child seat must be replaced if it was damaged or was stressed in an accident.
  - ▷ The child seat must not be used without a cover. Make sure to use only a genuine cover, because the cover is an essential part of the system function.
- 

### NOTICE

Risk of damage due to improper cleaning.

- ▷ Please observe the instructions on the cover's laundry label. If the cover is washed at a temperature higher than 30°C (86°F), the cover fabric may bleed.
- ▷ Do not spin-dry the cover and **never** dry it in an electric dryer (the fabric could separate from the cushion).
- ▷ You can clean the **plastic parts** and **belts** with a soap solution. **Do not** use any aggressive agents (e.g. solvents).

---

You can remove the **cover** and machine-wash it with mild detergent at 30°C (86°F) in the gentle cycle.

## Removing and Fitting the Covers

The cover for the Porsche Junior Seat LATCH consists of two parts. The Porsche Junior Seat LATCH must be taken out of the vehicle in order to remove the covers.

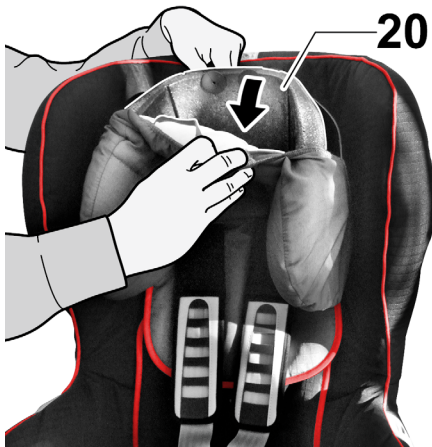

### Removing the Headrest Cover

1. Tilt the headrest forward.
2. Remove the headrest cover (20).
3. Thread the headrest cover out of the belts.



### Removing the Seat Cushion Cover

1. Move the headrest (20) to the middle position (refer to section "Adjusting the headrest").
2. Loosen the belts as much as possible (refer to section "Buckling in your child", step 1).
3. Open the buckle (24) (press on the red button) and move the belts to the outside.



4. Open the Velcro fastener on the groin pad (29) and remove it.

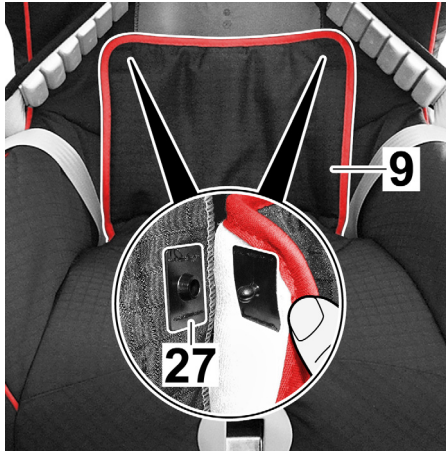

5. Open the snap fasteners (27) on the left and right sides of the back part (9) of the cover.



6. Fold the back part (9) of the seat cushion cover onto the seat surface.  
 7. Thread the belts out of the openings in the seat cushion cover.  
 8. Disengage the elastic seat cushion cover edge at the lower edge of the seat shell.

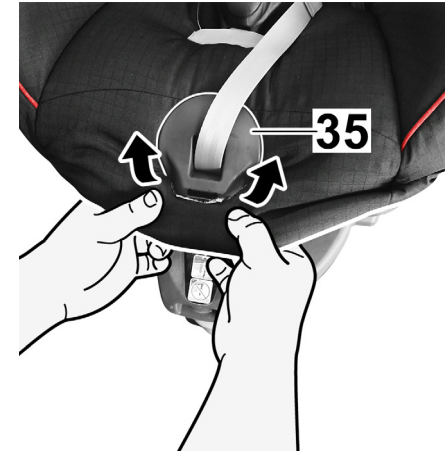

9. Pull the cover over the trim (35) of the belt adjuster from below.



10. Thread the buckle (24) and the belt end (36) out of the seat cushion cover.
11. Pull the seat cushion cover upward slightly and push its opening over the headrest (20).

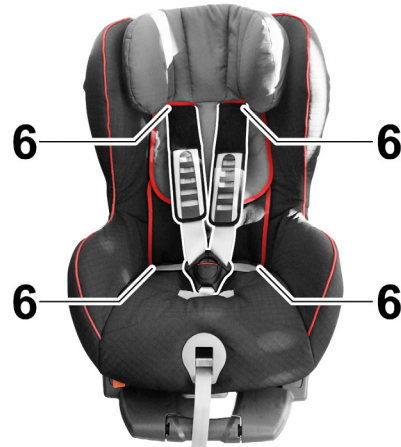

### Fitting the Covers

1. Fit the covers in the reverse order.

#### Information

Make sure that the belts are not twisted and are fitted correctly in the belt slots (6) of the cover.

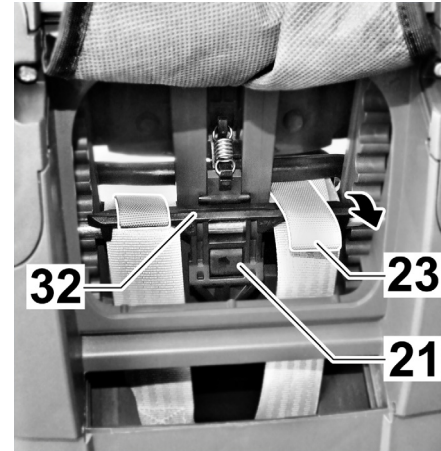

### Removing the Belts

1. Remove the seat cover.
2. Tilt the headrest forward and push the belt loops of the shoulder pads (23) off the bridge (32) of the headrest adjuster (21).

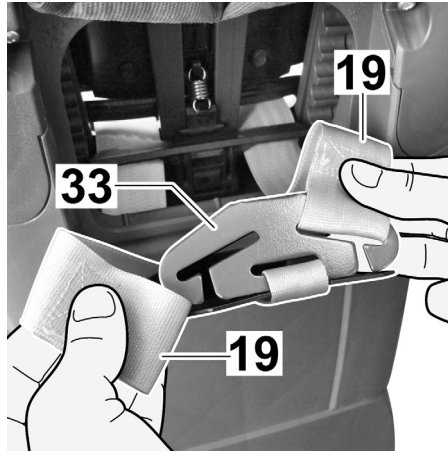

3. Disengage the shoulder belts (19) from the connecting piece (33).



**CAUTION** Connecting Piece

Risk of injury when removing the connecting piece (33) from the seat lower section.

- ▷ The disengaged connecting piece must not slip into the seat lower section.
- ▷ Hang the connecting piece over the seat lower section.

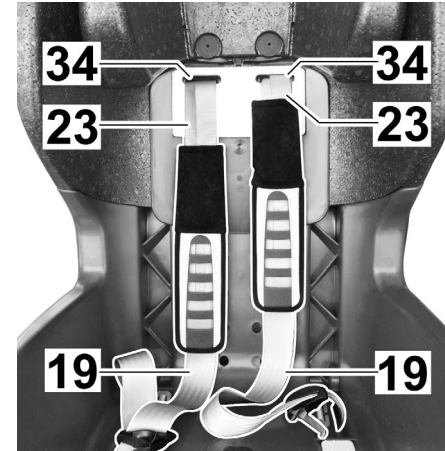

4. Pull the shoulder belts (19) and the belt loops of the shoulder pads (23) out of the belt slots (34).

5. Pull the shoulder pads (23) off the shoulder belts (19).



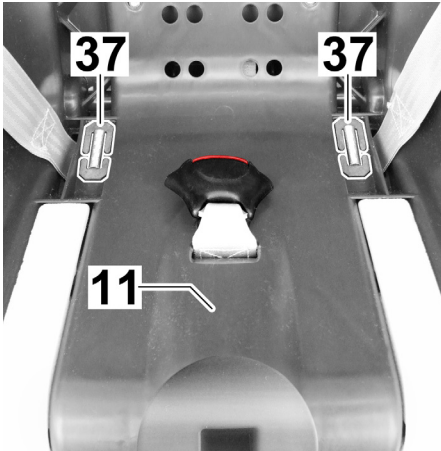

6. Pull out the metal plate (37) with which the belt is fastened at the bottom of the seat shell (11).

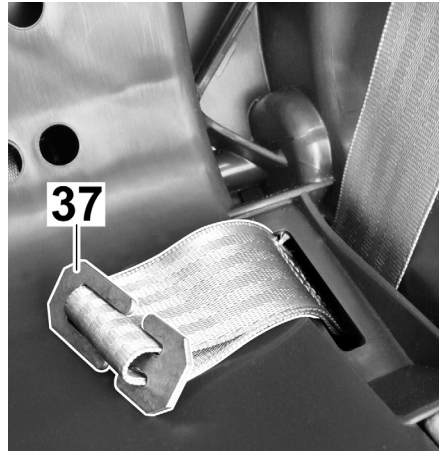

7. Push the belt loop back on the short side of the metal plate (37) and disengage the metal plate.  
8. You can now pull the belts out.

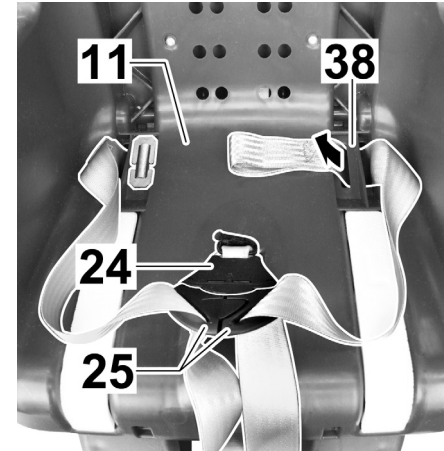

### Installing the Belts

1. Insert the belt tongues (25) into the buckle (24).
2. Now thread the long belt loop into the outer side slot (38) of the seat shell (11).

#### Information

Do not twist the belts.



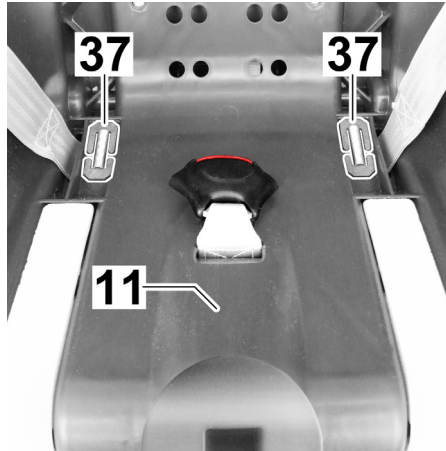

3. Engage the metal plate (37) in the long belt loop (engage the long side of the metal plate first, then the short side).
4. Pull on the belt until the metal plate (37) lies straight in the opening of the seat shell.
5. Open the buckle again.



6. Thread the shoulder pads (23) onto the shoulder belts (19).

**i** Information

Do not twist the shoulder belts.

**⚠ WARNING** Belt Straps

Damaged belt straps can tear in an accident and severely injure your child.

- ▷ Do not use any sharp or pointed objects when threading in the belts.
- ▷ Damaged belt straps must be replaced.

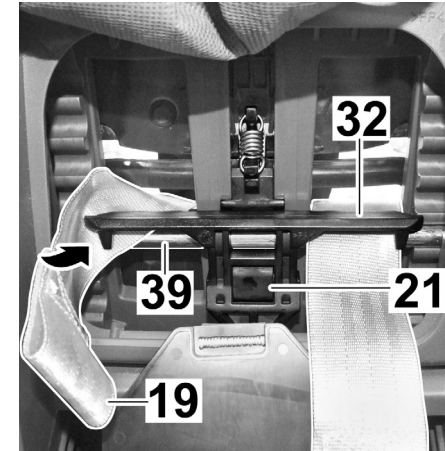

7. Thread the shoulder belts into the belt slots. Push the shoulder belts (19) through between the deflection rod (39) and the bridge (32) of the headrest adjuster (21).

**i** Information

Do not twist or interchange the shoulder belts.

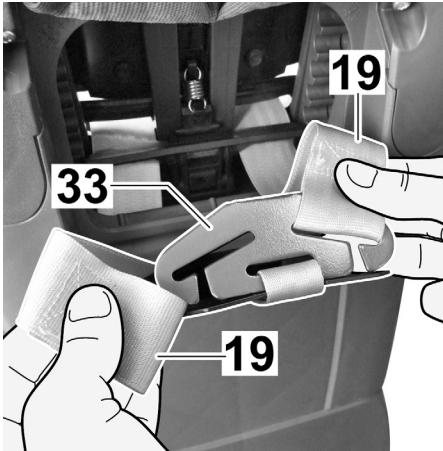

8. Engage the shoulder belts (19) into the connecting piece (33) again.

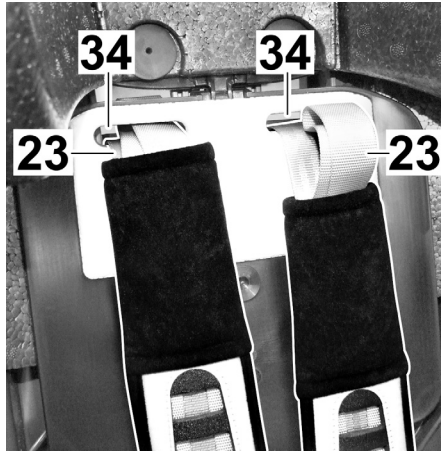

9. Thread the belt loops of the shoulder pads (23) into the belt slots (34) belt slots.

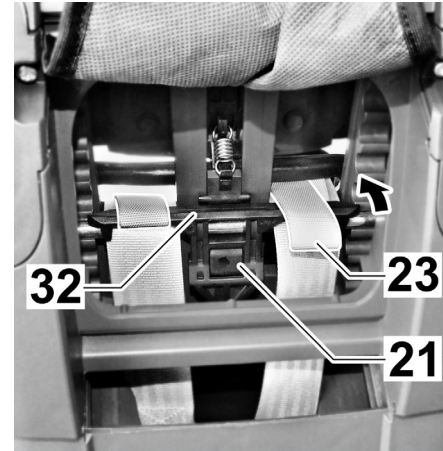

10. Tilt the headrest forward and push the belt loops of the shoulder pads (23) onto the bridge (32) of the headrest adjuster (21).  
11. Fit the seat cover.

## **Buckle Care**

A functioning buckle makes an important contribution to safety. Malfunctions of the buckle are mostly due to contamination.

### **Malfunction:**

- The belt tongues are ejected slowly when the red button is pressed.
- The belt tongues no longer lock into place (they are ejected again).
- The belt tongues engage without a clearly audible "click".
- The belt tongues encounter resistance when being inserted (doughy).
- The buckle can be opened only with great effort.

### **Remedy:**

This is how to wash out the buckle to make it function properly again.

- 1.** Remove the buckle.
  - ▷ Loosen the belts.
  - ▷ Open the Velcro fastener on the groin pad and remove it.
  - ▷ Move the child seat to idle position.
  - ▷ Disengage the elastic seat cushion cover edge at the lower edge of the seat shell.
  - ▷ Pull the seat cushion cover off the lower seat shell.



- ▷ Push the metal plate (30) with which the buckle (24) is fastened to the seat shell upright through the belt slot (31).

**2. Wash out the buckle.**

- ▷ Soak the buckle (24) in warm water with detergent for at least one hour. Then rinse the buckle out and allow it to dry thoroughly.

**3. Install the buckle.**

- ▷ Push the metal plate (30) in upright position through the belt slot (31) in the cover from top to bottom and through the seat shell. Firmly pull on the buckle (24) to check its attachment.
- ▷ Pull the seat cushion cover over the lower seat shell.
- ▷ Engage the elastic seat cushion cover edge at the lower edge of the seat shell.
- ▷ Thread the buckle and the belt end into the cover.
- ▷ Move the child seat to normal position.
- ▷ Fasten the groin pad.

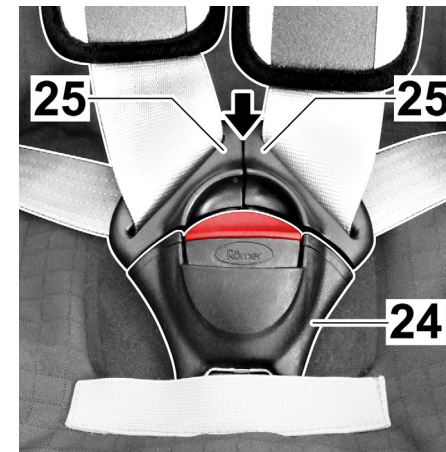

**Malfunction:**

- The belt tongues (25) can no longer be inserted into the buckle (24).

**Remedy:**

- Press the red button to release the buckle (24).



PORSCHE

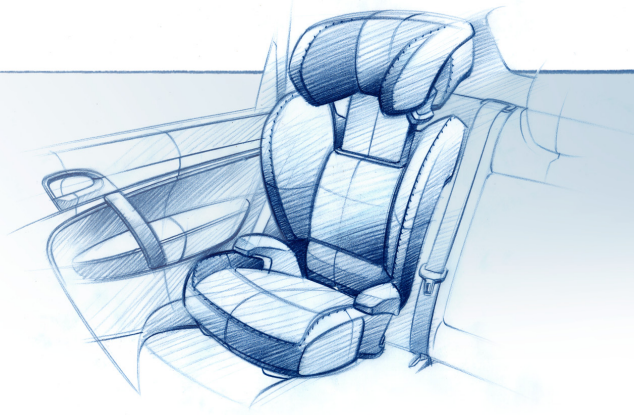

**Operation Instructions  
Porsche Junior Plus Seat G2 + G3**

**Thank you for purchasing your new Porsche Junior Plus Seat. How to use and take care of your child restraint plays an important role in the child's safety.**

**Please take the time to read these operating instructions carefully and keep them with the child restraint.**

These operating instructions provide you with important information on how to safely install and use the child restraint.



**Porsche Junior Plus Seat**

# Content

## **Safety Information**

Safety Information.....	82
-------------------------	----

## **Installation instructions**

Installation instructions .....	84
How to use Porsche Junior Plus Seat .....	84
The Porsche Junior Plus Seat be used in the listed vehicles .....	85
Components of the Porsche Junior Plus Seat .....	86
Fastening the Backrest.....	86
Seat Cushion Width .....	87
Adjusting the Seat Cushion Width .....	87
Headrest .....	88
Adjusting the Headrest .....	88
Adjusting the reclining position of the Backrest .....	89
Buckling in your Child .....	90
Fastening the Seat Belt .....	90
Securing your Child properly .....	93
Unfasten the Seat Belt .....	93

## **Cleaning and Maintenance**

Cleaning .....	95
Removing and Fitting the Covers .....	95
Removing the Backrest Cover .....	96
Removing the Seat Cushion Cover .....	96
Removing the Armrest Cover .....	96
Removing the Headrest Cover .....	97
Fitting the Covers .....	97

## Safety Information

### Child restraint on the front passenger seat

If you intend to use a child restraint on the front passenger' seat please refer to the vehicle Owner's Manual chapter „Child restraint systems“.

If your vehicle is equipped with a passenger airbag off system please take note of the green „AIRBAG OFF“ symbol on your child restraint.



If your vehicle is **not** equipped with a passenger airbag off system please take note of the red, circle and slash „AIRBAG OFF“ symbol on your child restraint.



If in doubt please see your authorized Porsche dealer.

### ⚠ WARNING

Danger of severe injuries if you abruptly change the direction of travel, brake heavily or have an accident.

- ▷ The child restraint's protective function is only ensured when the child restraint is both installed and used properly.
- ▷ Therefore, be sure to precisely follow each individual step of the operating instructions. Comply with the warning notes and safety precautions as well as the corresponding sections in the vehicle Owner's Manual.
- ▷ If you use the child seat on the rear seat, move the front seat as far forward as possible, so that the child does not come into contact with the front seat.
- ▷ Position the front seat backrest vertically.
- ▷ No modification may be made to child restraint, the safety belts or the fastening points.
- ▷ Since the cover represents an important part of the safety function, the child seat must not be used without the cover.
- ▷ You should pay particular attention to the information on the safety belts, airbags and child restraint systems.

### ⚠ DANGER

Danger of severe or mortal injuries if a two-point lap belt is used.

- ▷ Always use a three-point belt to secure your child.
- ▷ The vehicle's three-point seat belt must not be twisted or trapped.

### ⚠ WARNING

If the passenger front airbag is not switched off, only install the child safety seat in one of the rear seats that is suitable for this purpose.

- ▷ Please observe the chapter "Child restraint systems" in the vehicle Owner's Manual.
- ▷ If in doubt please see your authorized Porsche dealer.

### ⚠ WARNING

Deactivated passenger airbags do not provide any protection in an accident.

- ▷ Reactivate the passenger airbag after removing the child seat.



**⚠ WARNING**

Passenger airbags can cause severe or mortal injury to children when they are triggered.

- ▷ In all vehicles, it is impermissible to use the child seat on the front passenger seat without deactivating the passenger airbag.
  - ▷ Adjust the passenger seat to the rear and downmost seat position.
- 

**⚠ WARNING**

**Backrest**

Risk of injuries if the backrest folds back.

- ▷ Never use the child seat unsupported - not even when trying the seat out.
  - ▷ Always place the child seat on the vehicle seat before your child sits in it.
- 

**⚠ CAUTION**

**Hot Plastic Parts**

Danger of burns by hot plastic parts on the child seat if the seat was exposed to the sun.

- ▷ Protect the child seat against exposure to intense sunlight.
- 

**NOTICE**

Damage of child restraint. The child restraint is designed for transporting children.

- ▷ Do not place any heavy or sharp-edged objects in or on the child restraint, even if it has been removed from t
- 

**⚠ WARNING**

**Backrest**

Danger of severe or mortal injuries if there are unsecured persons or objects in the vehicle.

Make sure that

- ▷ the backrest of the vehicle is locked.
  - ▷ all heavy and sharp-edged parts in the vehicle are secured.
  - ▷ all people in the vehicle are secured.
  - ▷ the child seat is secured with the three-point seat belt when it is not in use.
- 



**Information**

The Porsche Plus child seat is not designed for sideways facing seats. The Porsche Plus child seat **must not** be used on such seats.

---

## Installation instructions

### Suitability

The Porsche Junior Plus Seat is valid only for children who weigh between 40 - 80 pounds (15 - 36 kg) and whose height is 60 inches (152 cm) or less.

### Approval and Testing

This child restraint system conforms to all applicable Federal Motor Vehicle Safety standards.

This child restraint is not certified for aircraft use. It has been approved for safe use in vehicles with a three point (lap and shoulder) seatbelt system only.

The Porsche Junior Plus seat has been tested and approved as a combined seat cushion and backrest.



### Information

The Porsche Junior Plus Seat can not be used with a lower universal anchorage system.

Do not make any modifications to the Porsche Junior Plus Seats and do not use any unsuitable accessories. Otherwise the warranty will be rendered invalid.

## How to use your Porsche Junior Plus Seat

The Porsche Junior Plus Seat may only be installed in the following seats in the vehicle:

In the direction of travel	yes
Opposite the direction of travel	no
Secured with two-point seat belt (lap belt)	no
Secured with three-point seat belt	yes
On the front passenger seat	<sup>1)</sup> yes
On outer rear seats	yes
On centre rear seat (with three-point seat belt)	yes

<sup>1)</sup> Do not use this product on front passenger seat if the front-passenger airbag is active! Use the rear seat.

## The Porsche Junior Plus Seat be used in the listed vehicles

Refer to the vehicle Owner's Manual or your Porsche Dealer will provide information about your vehicle model.

### Securing with three-point seat belt

Vehicle type	as of Modelyear	Passenger seat	Rear seat		
			left	middle	right
Panamera	2009	<sup>1)</sup> yes	yes	—	yes
Cayenne	2003	<sup>1)</sup> yes	yes	yes	yes
Macan	2014	<sup>1)</sup> yes	yes	yes	yes
911	1998	<sup>1)</sup> yes	yes	—	yes
Boxster	1997	<sup>1)</sup> yes	—	—	—
Cayman	2006	<sup>1)</sup> yes	—	—	—

<sup>1)</sup> Never install this child restraint in the front passenger seat of a vehicle that has a passenger airbag, unless the airbag is switched off. When possible, it is strongly recommended that all child restraints be placed in the rear of the vehicle.

## Components of the Porsche Junior Plus Seat

The Porsche Junior Plus Seat consists of a seat cushion and a backrest with adjustable headrest. This combination provides the desired protection and comfort for your child.

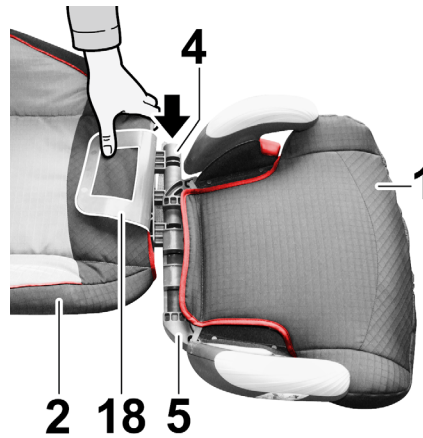

### Fastening the Backrest

1. Place the backrest (2) flat behind the seat cushion (1).
2. Fold the hinge cover (18) up.
3. Push the hinge axle (4) on the backrest as far as possible into the guide (5) on the seat cushion (arrow).

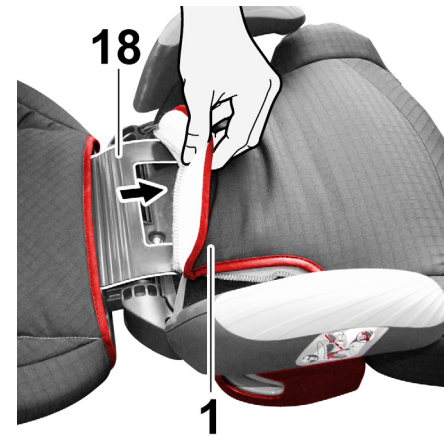

4. Push the hinge cover (18) under the cover of the seat cushion (1) so that the hinge cover rests on the plastic surface. If necessary, unhook the seat cushion cover.

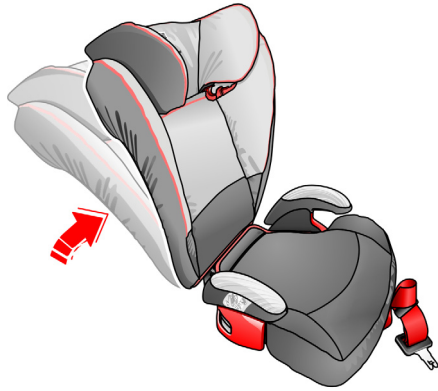

5. Swivel the backrest up until it locks into place.

**⚠ WARNING**

Backrest

Danger of injury when swivelling the backrest up.

- ▷ When swivelling the backrest, keep fingers and other parts of the body away from the area of the hinge axle.
- ▷ Swivel the backrest up with both hands.

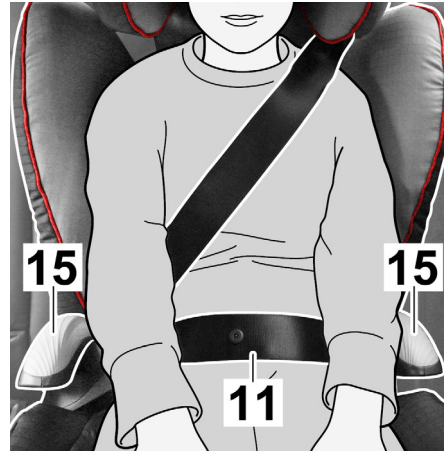

**Seat Cushion Width**

A correctly adapted seat cushion ensures that the lap belt (11) can be positioned properly, thereby enhancing the protection for your child. You can adjust the side pieces (15) of the seat cushion in **three** widths.

The seat cushion must be adjusted so that the adjustable side pieces are as close as possible to your child's pelvis without constricting it.

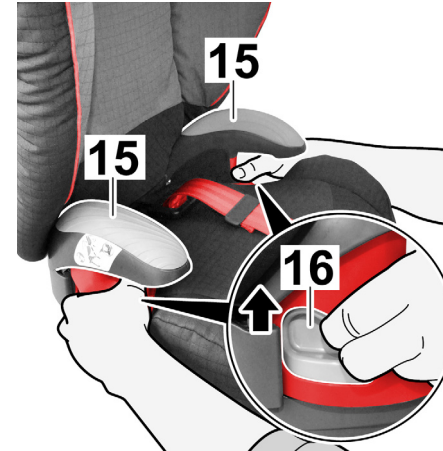

**Adjusting the Seat Cushion Width**

1. Grasp into the light grey adjustment buttons (16) on the outer side of the armrest (15) on both sides.
2. Push both adjustment buttons (16) up and pull the armrests (15) to the widest position.

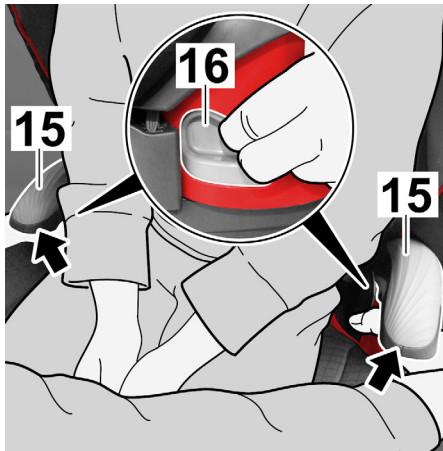

3. Have your child sit in the Porsche Junior Plus Seat.

**⚠ WARNING** Backrest

The child might be injured if the backrest tips backward.

- ▷ Make sure that the backrest of the Porsche Junior Plus Seat is leaning directly against the backrest of the vehicle seat and cannot tip backward.

4. Push both adjustment buttons (16) up again and position the armrests (15) to the desired width.

**i Information**

Check whether the armrests are engaged. To do this, pull the armrests outward or push them inward.

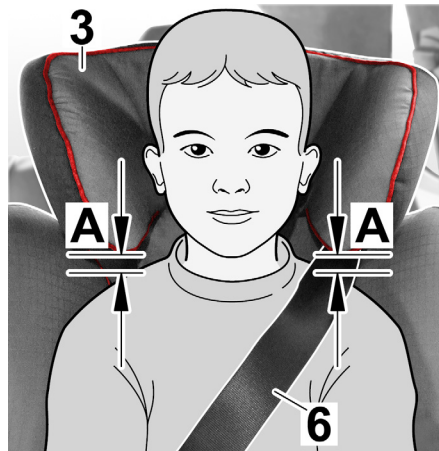

**Headrest**

A correctly adapted headrest (3) ensures that the diagonal belt (6) can be positioned properly and provides the desired protection and comfort for your child. The Porsche Junior Plus Seat features eleven detent positions to set the ideal height of the headrest (3).

**⚠ DANGER** Adjustment Headrest

Danger of severe or mortal injuries in the neck area if the headrest position is too low.

- ▷ Adjust the headrest (3) so that there is too little space of approx. 4 cm or 1.6 inches (width of two fingers) between your child's shoulders and the headrest (A).



**Adjusting the Headrest**

1. Grasp the adjusting handle (8) on the back of the headrest (3) and pull it up slightly. The headrest is now unlocked.
2. You can now adjust the unlocked headrest (3) to the desired height. The headrest (3) will lock as soon as you release the adjusting lever (8).
3. Place the Porsche Junior Plus Seat on the rear vehicle seat.
4. Have your child sit in the seat, and check the height.

**i Information**

Repeat this until the headrest (3) is ideally adjusted.

## Adjusting the reclining position of the Backrest

The backrest of the Porsche Junior Plus Seat adjust smoothly to the angle of the vehicle seat backrest. The backrest of the Porsche Junior Plus Seat can also be reclined.

### **WARNING**

#### Incorrectly Installed Child Seat

An incorrectly installed child seat may not be able to protect the child as intended and may cause serious or fatal injury to the child if you brake sharply, change direction suddenly or have an accident.

- ▷ The backrest of the Porsche Junior Plus Seat may only be tilted so far backward that the spacer bar lies flat against the backrest of the vehicle seat.
- ▷ The best possible protection is ensured only if the vehicle seat is in upright position.

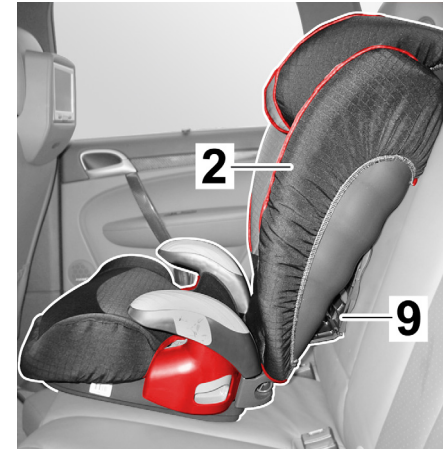

1. Lift the Porsche Junior Plus Seat onto the rear vehicle seat.
2. Pull spacer bar (9) downward/thereby folding it out of backrest (2).
3. Hold seat cushion (1) and push backrest (2) backward past the point of resistance.
4. To do this, unfold the spacer bracket (9) on the back of the backrest (2).

5. Slide the Porsche Junior Plus Seat up to the backrest of the vehicle seat, until spacer bar (9) is lying flat against the backrest of the vehicle seat.

### **Information**

Do not tilt the backrest further than permitted by the spacer bracket.

## Buckling in your Child

The Porsche Junior Plus Seat does not have to be installed in the vehicle. Your child is simply secured in the child seat by the vehicle's three-point seat belt.



### Fastening the Seat Belt



**DANGER**

Two-point Lap Belt

Danger of severe or mortal injuries if a two-point lap belt is used.

- ▷ Always use a three-point belt to secure your child.

1. Place the Porsche Junior Plus Seat on the vehicle seat. Make sure that the backrest (2) lies flat on the backrest of the vehicle seat (backrest idle position).

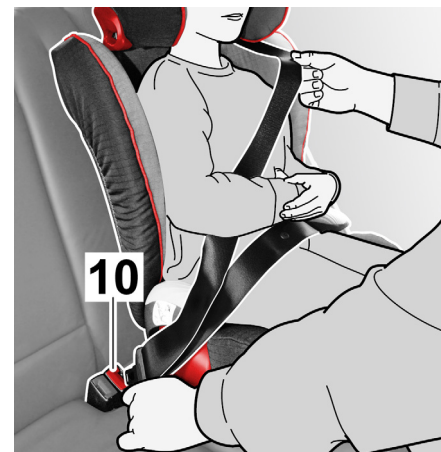

2. Have your child sit in the Porsche Junior Plus Seat.



**WARNING**

Twisted Shoulder Belts

Twisted or interchanged shoulder belts can severely injure your child.

- ▷ Do not twist or interchange the shoulder belts.

3. Pull the seat belt out and guide it in front of your child to the buckle (10).
4. Insert the belt tongue into the buckle (10) so that you hear it engage.



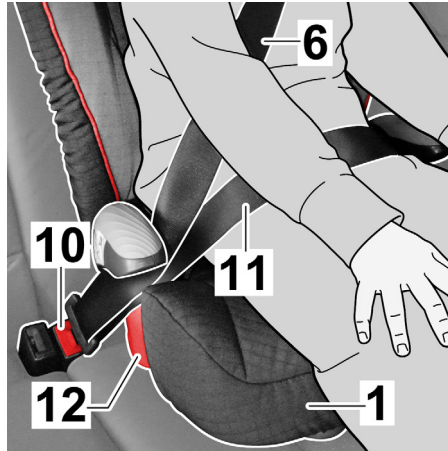

5. Place the diagonal belt (6) and the lap belt (11) on the buckle (10) side under the armrest and into the light red belt guide (12) of the seat cushion (1).

**i** Information

The buckle (10) must not be positioned between the light red belt guide (12) and the armrest.

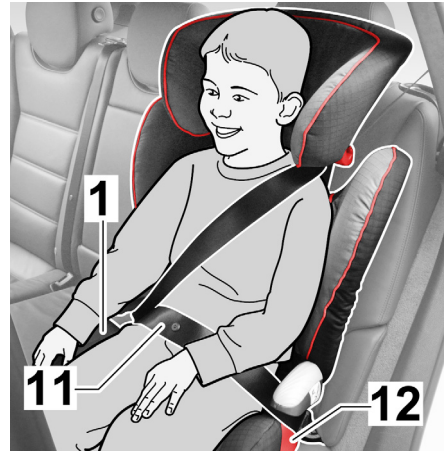

6. Also place the lap belt (11) on the other side of the seat cushion (1) into the light red belt guide (12).

**i** Information

The lap belt (11) must be positioned as low as possible over your child's hips on both sides.

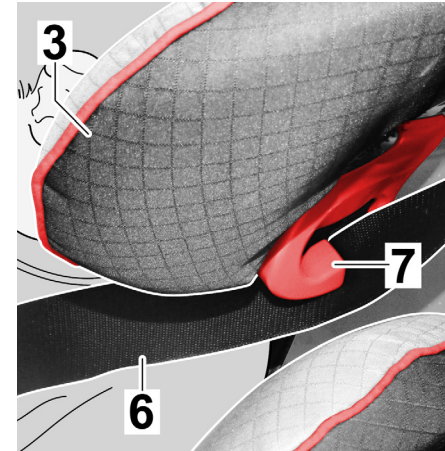

7. Insert the diagonal belt (6) into the dark red belt holder (7) of the headrest (3) until the diagonal belt lies completely in the belt holder without twisting.

**i** Information

If the backrest covers the belt holder, you can adjust the headrest upward. The shoulder belt can now be inserted easily. Now return the headrest to its original height.



**⚠ DANGER** Misuse Three-point Seat Belt

Danger of severe or mortal injuries in the neck area if the three-point seat belt is positioned too high.

- ▷ Make sure that the diagonal belt (6) is positioned over the clavicle of your child and does not rest on the neck.
- ▷ Tighten the belt by pulling on the diagonal belt.
- ▷ You can also adjust the headrest (3) height in the vehicle.
- ▷ The shoulder belt must run diagonally to the rear.
- ▷ The belt position can be adapted with the adjustable belt deflector (if present) on the vehicle.

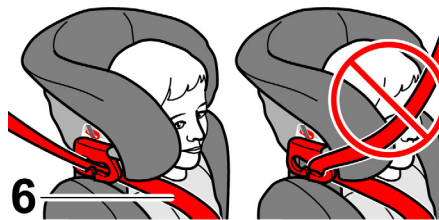

**⚠ DANGER** Misuse Three-point Seat Belt

Danger of severe injuries if the diagonal belt (6) runs forward to the belt deflector on the vehicle.

- ▷ In this case, please use the child seat on the rear seat.



### Securing your Child properly



**DANGER** Incorrectly Installed Child Restraint

An incorrectly installed child restraint cannot protect the child as intended in the event of an accident, sharp braking maneuvers or sudden changes of direction and may lead to serious or fatal injuries to the child or other vehicles occupants. In the interest of your child's safety, check that

- ▷ the lap belt (11) runs in the light red belt guides (12) on both sides of the seat cushion.
- ▷ the diagonal belt (6) on the buckle (10) side also runs in the light red belt guide (12) of the seat cushion.
- ▷ the diagonal belt (6) runs through the dark red belt holder (7) of the headrest.
- ▷ the diagonal belt runs diagonally to the rear.
- ▷ the seat belt is taut and not twisted.

- ▷ the buckle is not located between the light red belt guide and the armrest of the seat cushion.

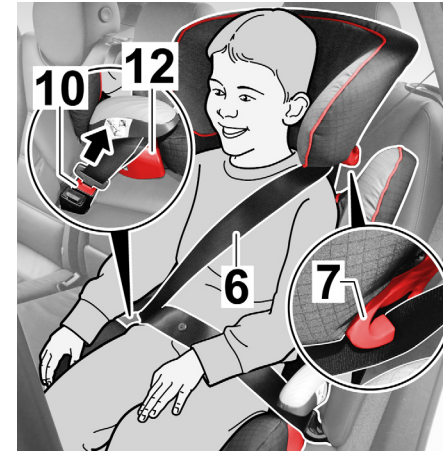

### Unfasten the Seat Belt

1. Press the belt release button of buckle (10) and pull the belt tongue of the three-point seat belt out of buckle (10).
2. Unthread diagonal belt (6) from red belt holder (7).
3. Guide the three-point seat belt out of red belt guides (12) to red belt holder (7).

**⚠ WARNING**

The children may be struck by following traffic and be seriously or fatally injured.

- ▷ Only allow children to get in or out of the vehicle on the side of the street that is facing away from the traffic
- ▷ Do not leave children unattended in the vehicle, even if they are fastened into a Porsche child seat. The children may open doors or injure themselves on moving parts in the vehicle or set the vehicle in motion.

- 
4. Secure the Porsche Plus child seat in place with the three-point seat belt even when the seat is not occupied.

## Cleaning

### WARNING

Danger of severe injuries if you abruptly change the direction of travel, brake heavily or have an accident.

- ▷ A damaged seat cover must be replaced.
  - ▷ The child seat must be replaced if it was damaged or was stressed in an accident.
  - ▷ The child seat must not be used without a cover. Make sure to use only a genuine cover, because the cover is an essential part of the system function.
- 

### NOTICE

Risk of damage due to improper cleaning.

- ▷ Please observe the instructions on the cover's laundry label. If the cover is washed at a temperature higher than 30°C (86°F), the cover fabric may bleed.
  - ▷ Do not spin-dry the cover and **never** dry it in an electric dryer (the fabric could separate from the cushion).
  - ▷ You can clean the **plastic parts** with a soap solution. **Do not** use any aggressive agents (e.g. solvents).
- 

You can remove the **cover** and machine-wash it with mild detergent at 30°C (86°F) in the gentle cycle.

## Removing and Fitting the Covers

The cover for the Porsche Junior Plus Seat consists of four parts. The parts can be removed individually. The Porsche Junior Plus Seat must be taken out of the vehicle in order to remove the cover.



### Information

Since the cover represents an important part of the safety function, the child seat must not be used without the cover.

---

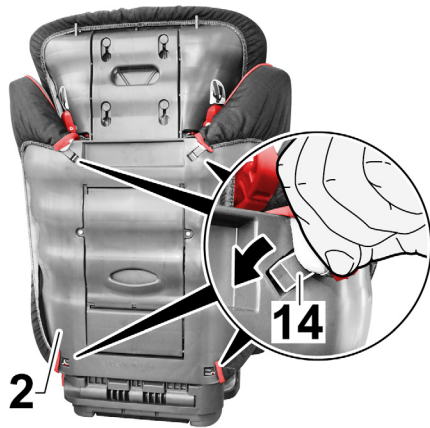

### Removing the Backrest Cover

1. Unhook the hook (14) of the backrest (2) and pull the hooks off the backrest.

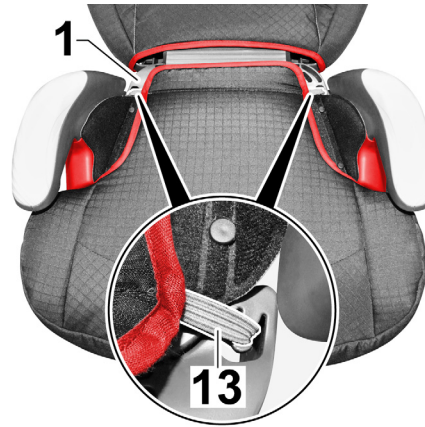

### Removing the Seat Cushion Cover

1. Push the backrest back slightly to release the catch (not visible) and fold the backrest down.
2. Unhook the rubber loops (13) of the seat cushion and pull the seat cushion cover off the seat cushion (1).

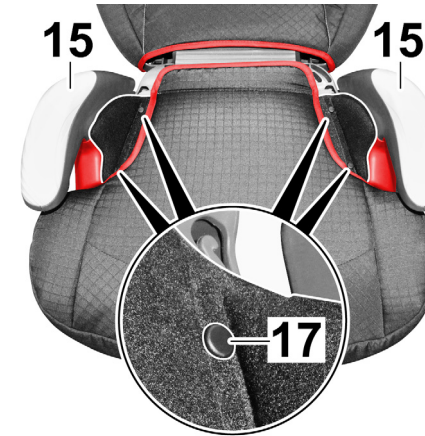

### Removing the Armrest Cover

1. Pull the pins (17) out of the armrest cover (15) and remove the armrest cover.



### Removing the Headrest Cover

1. Pull the headrest out.
2. Unhook the hooks (14) from the backrest (2).



### Fitting the Covers

1. Fit the covers in the reverse order.

3. Undo the buttonholes (19) of the headrest (3) and remove the headrest cover.

## Instruction for disposal

Please follow the disposal regulations for your country as well as the following disposal instructions. Ensure that the packaging and the individual parts are disposed of in the correct material containers.

<b>Disposal of the packaging</b>	
Cardboard boxes	Collection container for cardboard
<b>Disposal of individual parts</b>	
Cover	Residual waste, incineration
Plastic parts	Disposal in the appropriate containers according to the identification
Metal parts	Collection container for metals
Belt strap	Collection container for polyester
Buckle & tongue	Residual waste



## **Recall Information USA**

Child restraints could be recalled for safety reasons. You must register this restraint to be reached in a recall. Send your name, address, e-mail address if available and the restraint's model number and manufacturing date to:

Porsche Cars North America, Inc.  
980 Hammond Drive, Suite 1000  
Atlanta, GA 30328

or call:

1-800-PORSCHE

For recall information call the  
U.S. Government's Vehicle Safety Hotline at:  
1-888-327-4236  
(TTY: 1-800-424-9153),  
or go to <http://www.NHTSA.gov>.

## **Limited Warranty USA**

Porsche Cars North America, Inc. (PCNA), warrants this product to the original retail purchaser as follows:

### **LIMITED TWO-YEAR WARRANTY:**

This product is warranted against defective materials or workmanship for two years from the date of the original purchase. Proof of purchase is required.

No person, agent distributor dealer or company is authorized to change, modify or extend the terms of this warranty in any manner whatsoever or to assume any other liability in connection with the product.

Your exclusive remedy for this warranty is that PCNA will, at its option, provide repair or replacement components for this product or refund the original purchase price of the product. PCNA reserves the right to discontinue or change fabrics, parts, models or products, or to make substitutions. To make a claim under this warranty you must contact your Porsche dealership or call:

1-800-PORSCHE

Proof of purchase is required.

Please complete and mail the preaddressed owner registration card within thirty (30) days of purchase.

### **WARRANTY LIMITATIONS:**

The remedies available under this warranty do not extend to damage to the product caused by negligence, misuse or use that is not in accordance with product instructions.

### **LIMITATION OF DAMAGES:**

The warranty and remedies as set forth above are exclusive and in lieu of all other warranties, representations, conditions, guarantees and other obligations, oral or written, express or implied including, but not limited to, implied warranties of merchantability or fitness for a particular purpose. In no event will PCNA or the retailer selling this product be liable to you for any damages, including incidental or consequential damages, arising out of the use or inability to use this product.

